

# Magnetic Resonance in Quantum Information

Christian Degen

Spin Physics and Imaging group  
Laboratory for Solid State Physics

[www.spin.ethz.ch](http://www.spin.ethz.ch)

# Content

Features of (nuclear) magnetic resonance

Brief History of NMR

Example 1:

Liquid-state NMR ( $\Rightarrow$  Factoring of 15)

Example 2:

Quantum information using single spins in diamond

# Magnetic nuclei

Blue => Nuclei with spin  $I = \frac{1}{2}$

Red => Nuclei with spin  $I > \frac{1}{2}$

Grey => Nuclei with spin zero, or not known

H																	He
Li	Be											B	C	N	O	F	Ne
Na	Mg											Al	Si	P	S	Cl	Ar
K	Ca	Sc	Ti	V	Cr	Mn	Fe	Co	Ni	Cu	Zn	Ga	Ge	As	Se	Br	Kr
Rb	Sr	Y	Zr	Nb	Mo	Tc	Ru	Rh	Pd	Ag	Cd	In	Sn	Sb	Te	I	Xe
Cs	Ba	*	Hf	Ta	W	Re	Os	Ir	Pt	Au	Hg	Pb	Pb	Bi	Po	At	Rn
Fr	Ra	**	Rf	Db	Sg	Bh	Hs	Mt	Ds	Rg	Uub	Uut	Uuq	Uup	Uuh	Uus	Uuo

\* La Ce Pr Nd Pm Sm Eu Gd Tb Dy Ho Er Tm Yb Lu

\*\* Ac Th Pa U Np Pu Am Cm Bk Cf Es Fm Md No Lr

# Time and Energy scales in NMR & EPR

	<u>Nuclei</u> (Protons)	<u>Electrons</u>
• Relevant energy: Zeeman energy in magnetic field (up to ~24Tesla)	43 MHz/T (~0.2 $\mu$ eV/T)	28 GHz/T (~120 $\mu$ eV/T)
• Polarization (room temperature)	~10 <sup>-5</sup>	~1%
• Spin relaxation time T <sub>1</sub>	0.1...10 <sup>5</sup> s	10 <sup>-9</sup> ...1 s
• Spin coherence time T <sub>2</sub>	~1...100 $\mu$ s (solids) ~10ms...10s (liquids)	10 <sup>-9</sup> ...10 <sup>-3</sup> s
• Spin rotations (pulses)	~1-10 $\mu$ s	~1-100 ns
• Swaps (spin-spin couplings)	~10 $\mu$ s...10ms	~0.1-10 $\mu$ s

# NMR largely satisfies the DiVincenzo criteria

- ✓ Qubits: nuclear spins  $\frac{1}{2}$  in  $B_0$  field ( $\uparrow$  and  $\downarrow$  as 0 and 1)
- ✓ Quantum gates: RF pulses and delay times
- (✓) Input: Boltzmann distribution (room temperature)
- ✓ Readout: detect spin states with RF coil
- ✓ Coherence times: easily several seconds

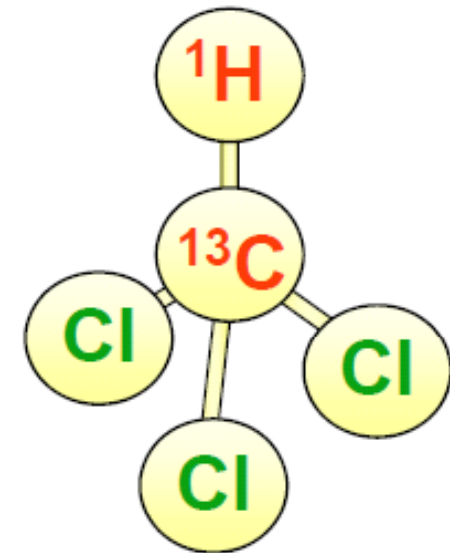
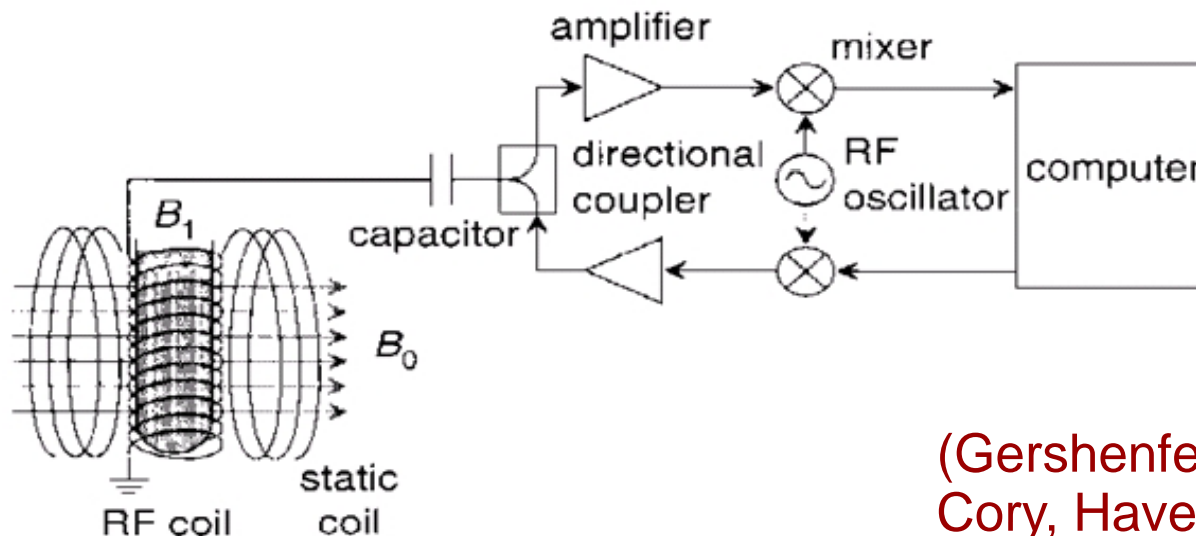

(Gershenfeld & Chuang 1997,  
Cory, Havel & Fahmi 1997)

# Brief history of NMR

Literature suggestion:

A. Abragam,

“Time reversal: An autobiography”

(Oxford University Press, 1989)

- 1922 Stern-Gerlach experiment
- 1939 Rabi's molecular beam experiment [[Nobel Prize 1944](#)]
- 1945-1950 Bloch equations [[Nobel Prize 1952](#)]
- 1950-1965 Physical basis of NMR: Relaxation, Couplings, DNP, etc.
- ~1965 Fourier-transform NMR (Ernst) [[Nobel Prize 1991](#)]
- 1973 Invention of magnetic resonance imaging [[Nobel Prize 2003](#)]
- ~1975 Multi-dimensional NMR
- 1975-1990 Advanced multi-pulse techniques (decoupling, ...)
- 1980- Application in Structural Biology [[Nobel Prize 2002](#)]
- 1995- Application in Quantum engineering

# Example 1: Liquid-state NMR



Principles of NMR QC

Techniques for qubit control

State of the art & Outlook

=> “NMR Quantum Computing”

Slides courtesy of **Lieven Vandersypen**

Then: IBM Almaden, Stanford University

Now: Kavli Institute of NanoScience, TU Delft

# How to factor 15 with NMR?

perfluorobutadienyl  
iron complex

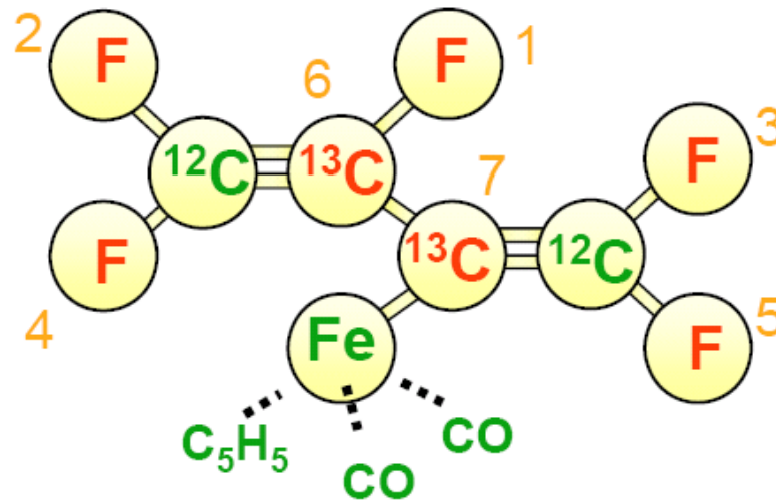

red nuclei are  
qubits: F, <sup>13</sup>C



# Liquid-state NMR

Survey of NMR quantum computing

➔ Principles of NMR QC

Techniques for qubit control

Summary: Pros & Cons

# Nuclear spin Hamiltonian

## Single spin 1/2

$$\mathcal{H}_0 = -\hbar\gamma B_0 I_z = -\hbar\omega_0 I_z = \begin{bmatrix} -\hbar\omega_0/2 & 0 \\ 0 & \hbar\omega_0/2 \end{bmatrix}$$

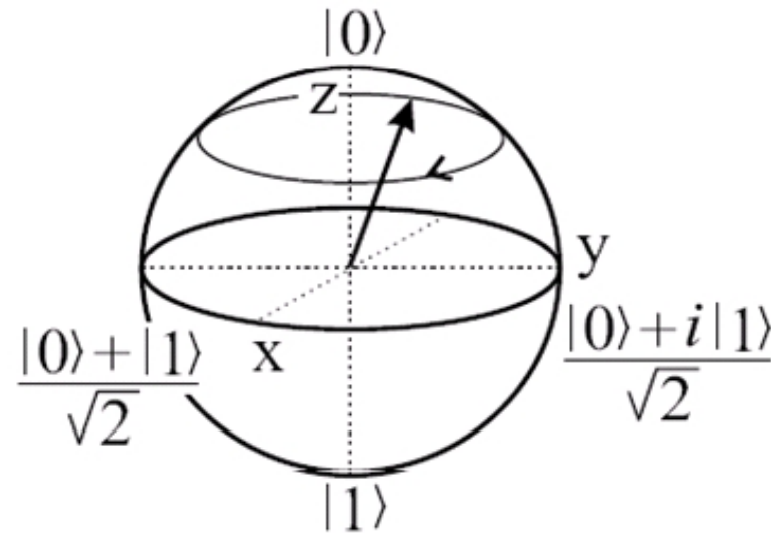
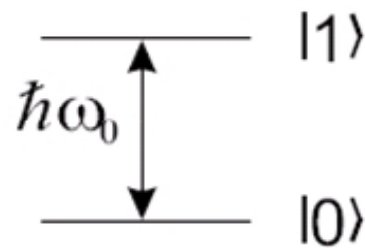

angular momentum:

$$\vec{L} = \hbar \vec{I}$$

magnetic moment:

$$\vec{M} = \gamma \hbar \vec{I}$$

energy:

$$\mathcal{H}_0 = -\vec{M} \cdot \vec{B}_0$$

gyromagnetic (g-)factor:  $\gamma$

# Nuclear spin Hamiltonian

## Multiple spins

without  
qubit/qubit  
coupling

$$\mathcal{H}_0 = - \sum_{i=1}^n \hbar (1 - \tilde{\sigma}_i) \gamma_i B_0 I_z^i = - \sum_{i=1}^n \hbar \omega_0^i I_z^i$$



chemical shifts  
of the five **F** qubits

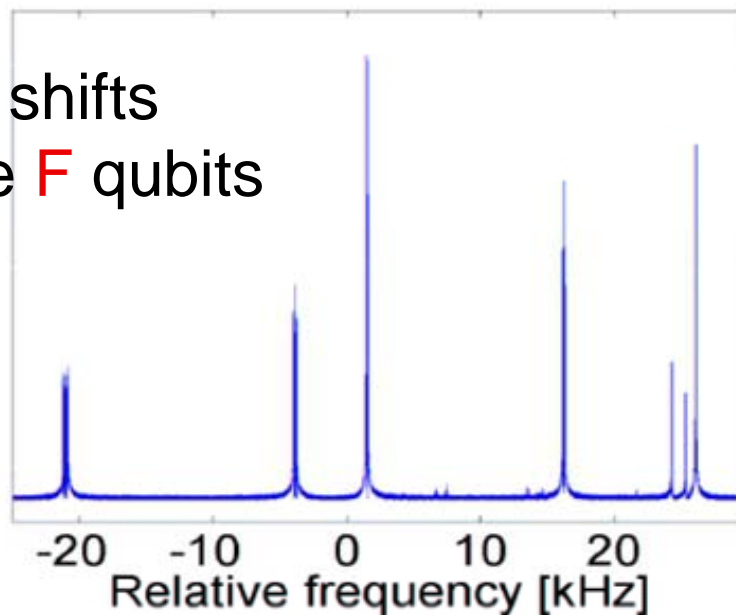

MHz

$^1\text{H}$  500 ~ 25 mK

$^{13}\text{C}$  126

$^{15}\text{N}$  -51

$^{19}\text{F}$  470

$^{31}\text{P}$  202

(at 11.7 Tesla)  
qubit level separation

# Hamiltonian with RF field single-qubit rotations

$$\mathcal{H} = -\hbar\omega_0 I_z - \hbar\omega_1 \left[ \overset{\sigma_x}{\cos(\omega_{rf}t + \phi)} I_x + \overset{\sigma_y}{\sin(\omega_{rf}t + \phi)} I_y \right]$$



$$|\psi\rangle^{rot} = \exp(-i\omega_{rf}t I_z) |\psi\rangle$$

$$\mathcal{H}^{rot} = -\hbar(\omega_0 - \omega_{rf}) I_z - \hbar\omega_1 \left[ \cos \phi I_x + \sin \phi I_y \right]$$

rotating wave approximation

typical strength  $I_x, I_y$  : up to 100 kHz

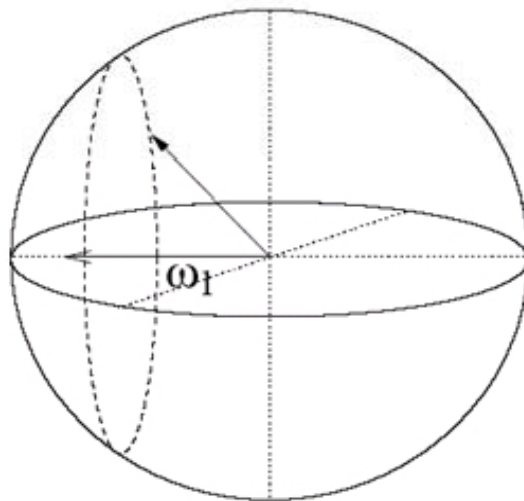

Rotating frame

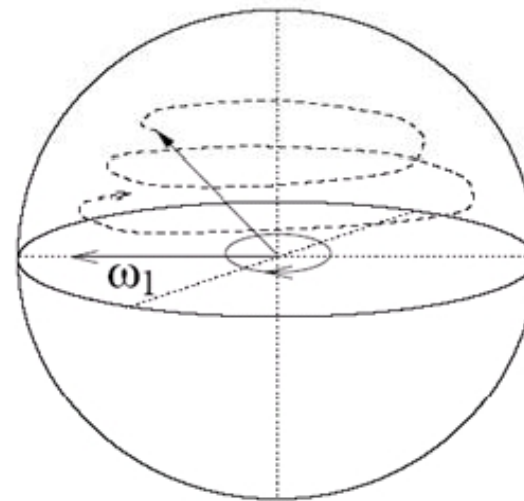

Lab frame

# Nuclear spin Hamiltonian

**Coupled spins**  $J > 0$ : antiferro mag.

$J < 0$ : ferro-mag.

coupling term

$$\mathcal{H}_J = \hbar \sum_{i < j}^n 2\pi J_{ij} I_z^i I_z^j$$

Typical values:  $J$  up to few 100 Hz

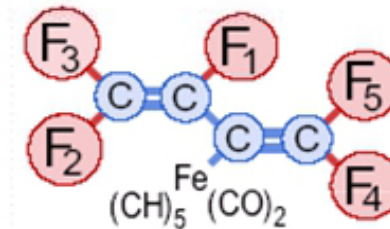

16 configurations

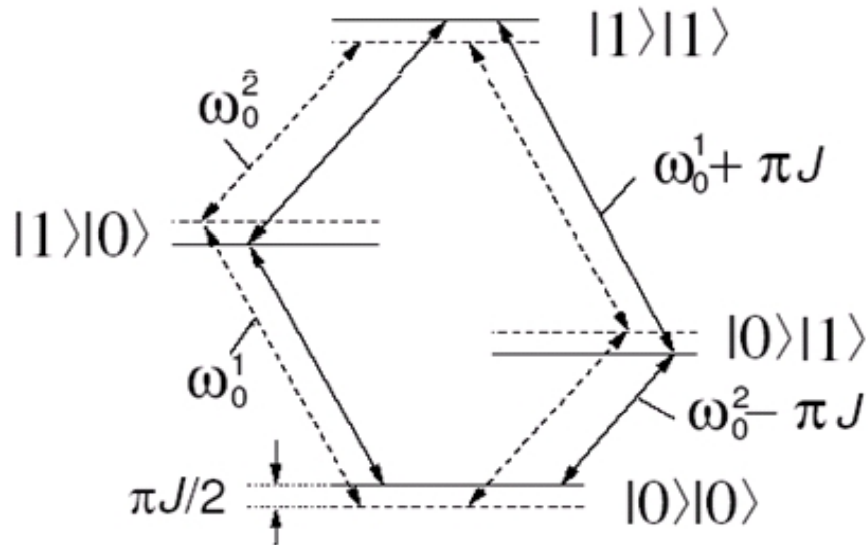

solid (dashed) lines are (un)coupled levels

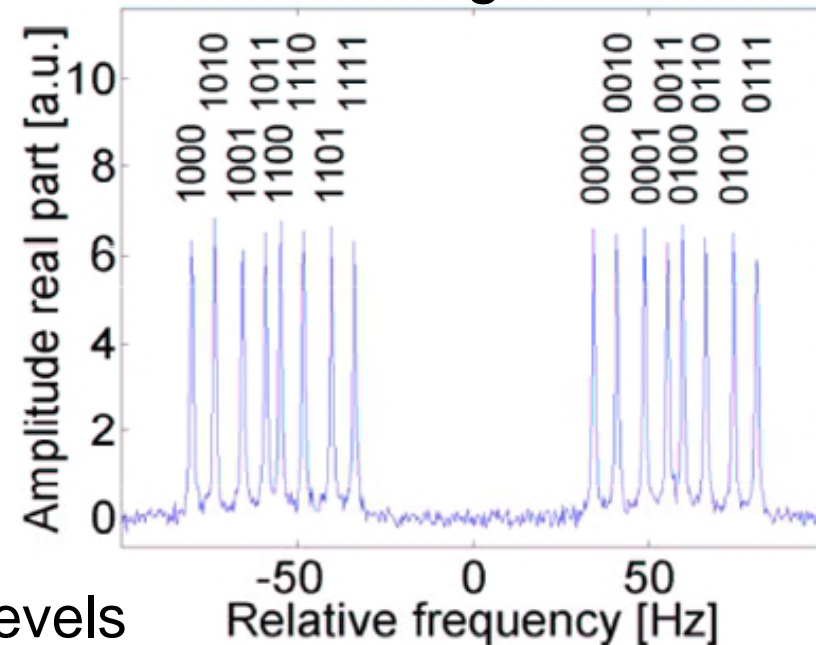

# Controlled-NOT in NMR

A target bit  
B control bit

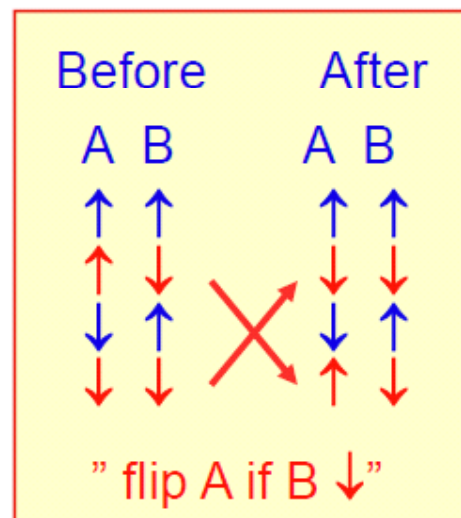
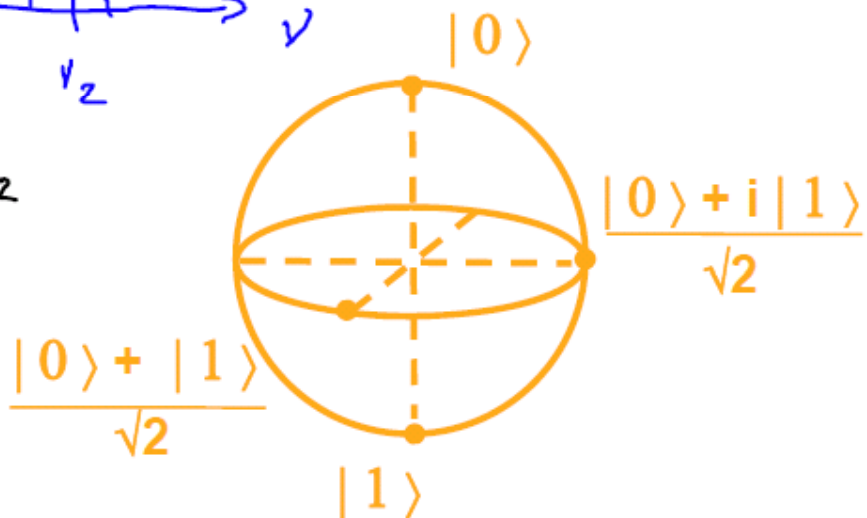
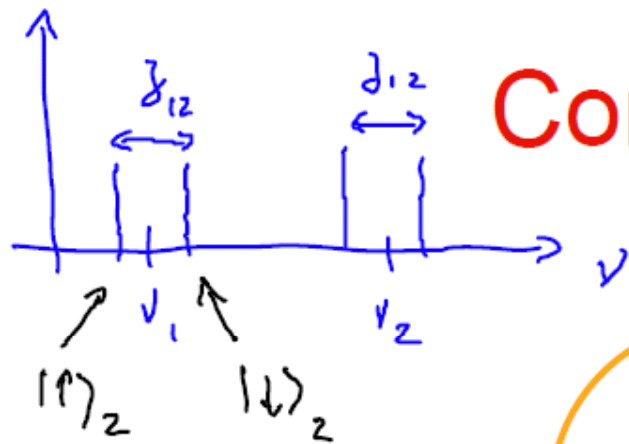

if spin B is ↑

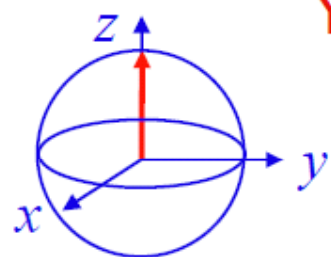

$Y^A_{90}$

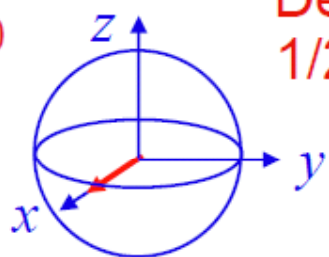

wait  
Delay  
 $1/2J_{AB}$

$X^A_{90}$

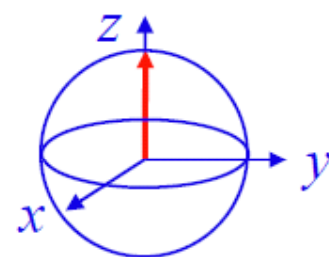
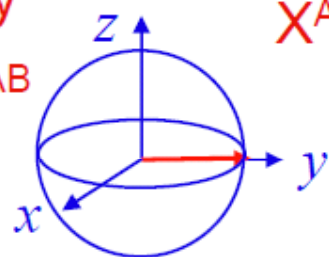

if spin B is ↓

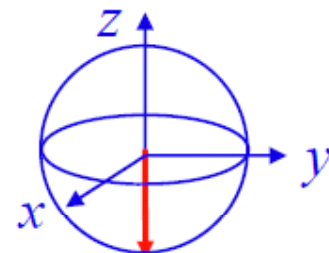
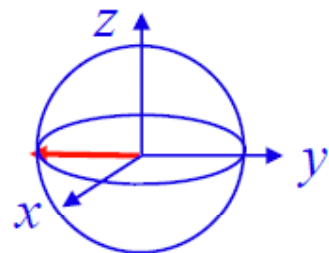
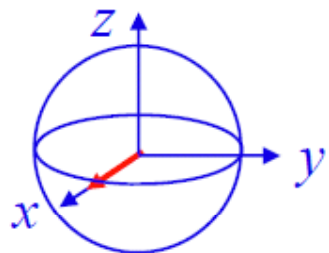
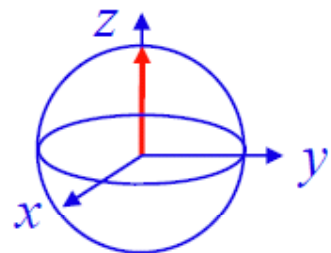

different rotation direction depending on control bit

time

# Making room temperature spins look cold

- (Cool to mK)
- Optical pumping
- DNP, ...

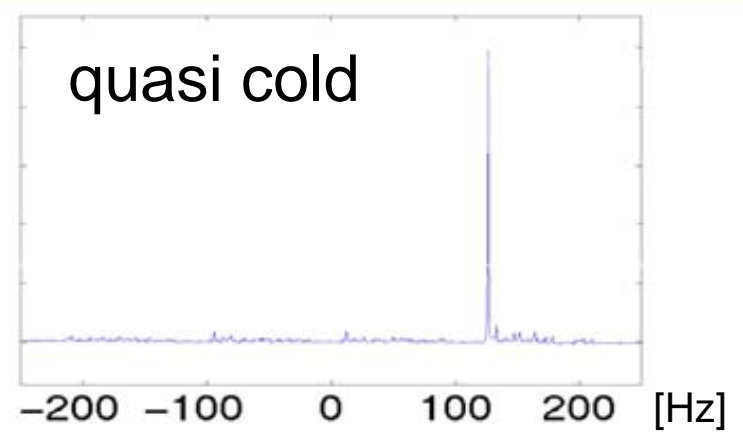
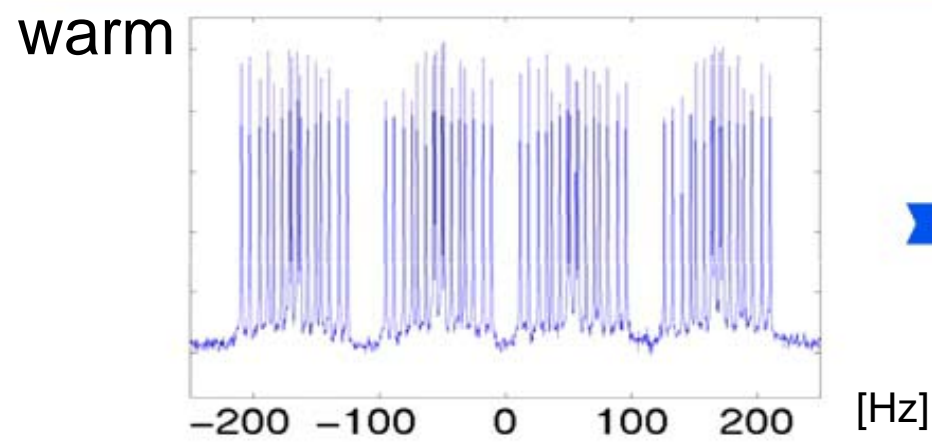
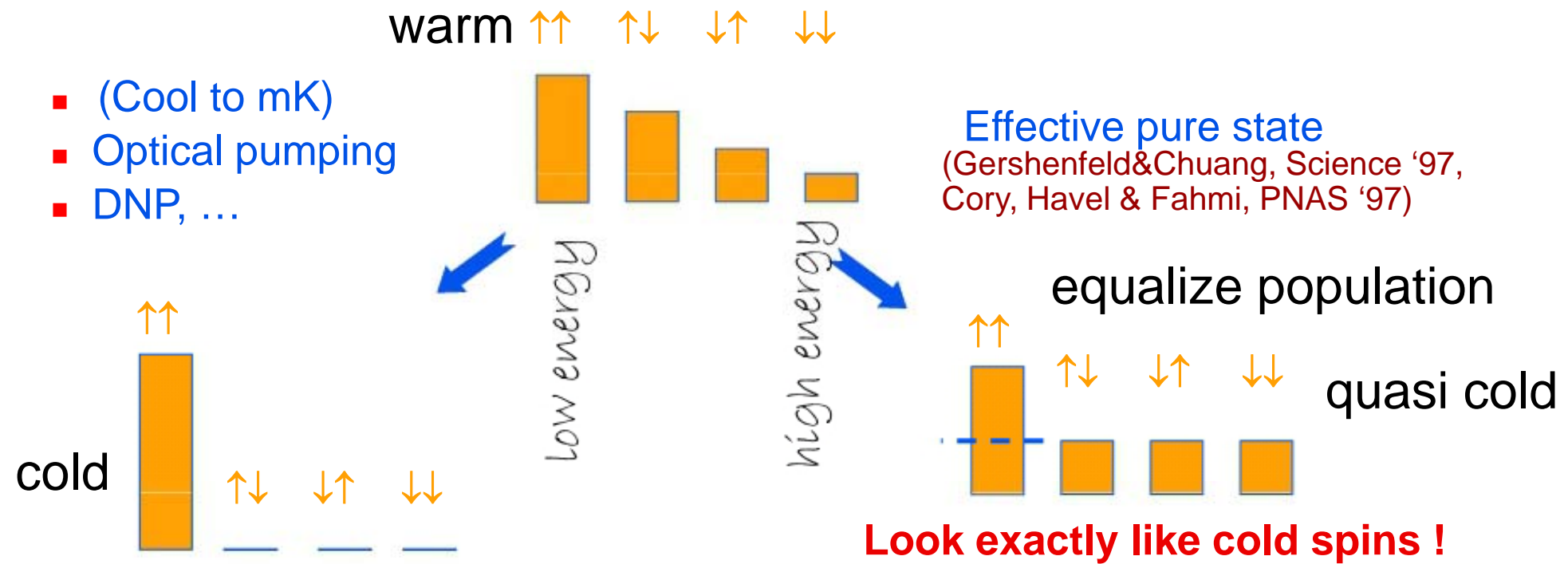

# Effective pure state preparation

(1) Add up  $2^N - 1$  experiments (Knill, Chuang, Laflamme, PRA 1998)

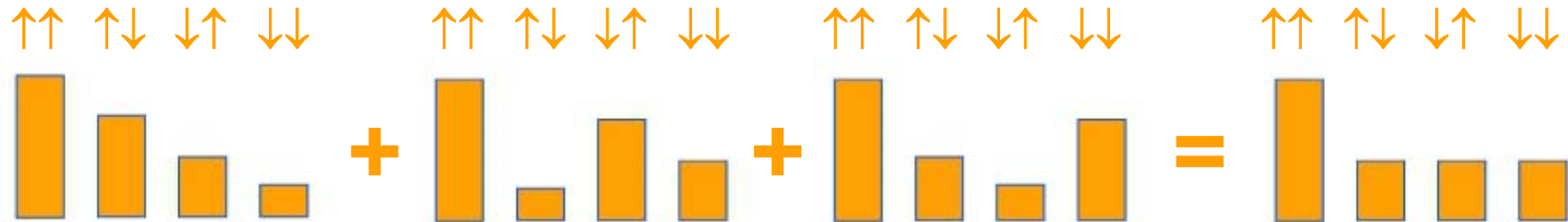

Later :  $(2^N - 1) / N$  experiments (Vandersypen *et al.*, PRL 2000)  
prepare equal population (on average) and look at deviations from equilibrium.

(2) Work in subspace (Gershenfeld & Chuang, Science 1997)



compute with qubit states that have the same energy and thus the same population.



# Read-out in NMR

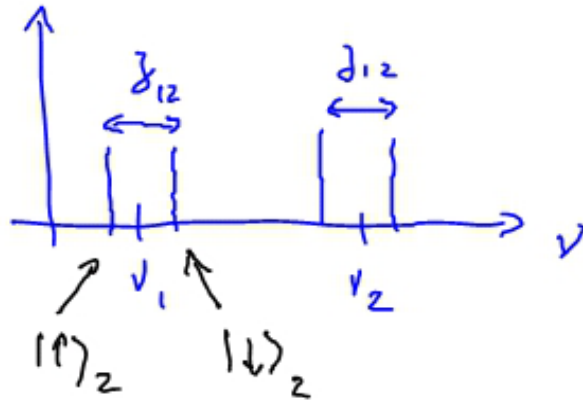

Phase sensitive detection

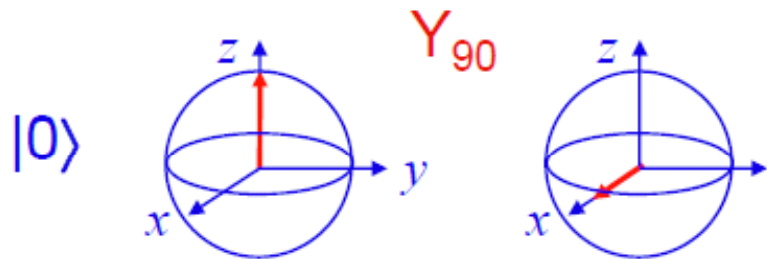

positive signal for  $|0\rangle$  (in phase)

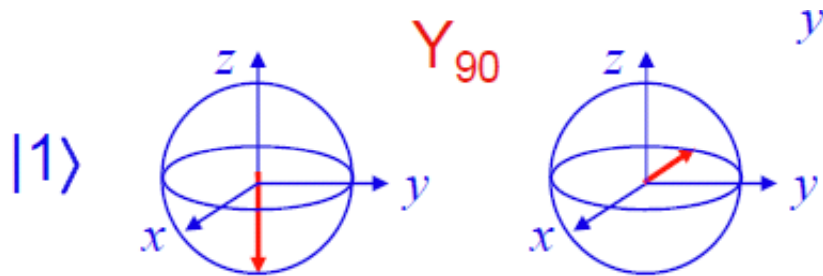

negative signal for  $|1\rangle$  (out of phase)

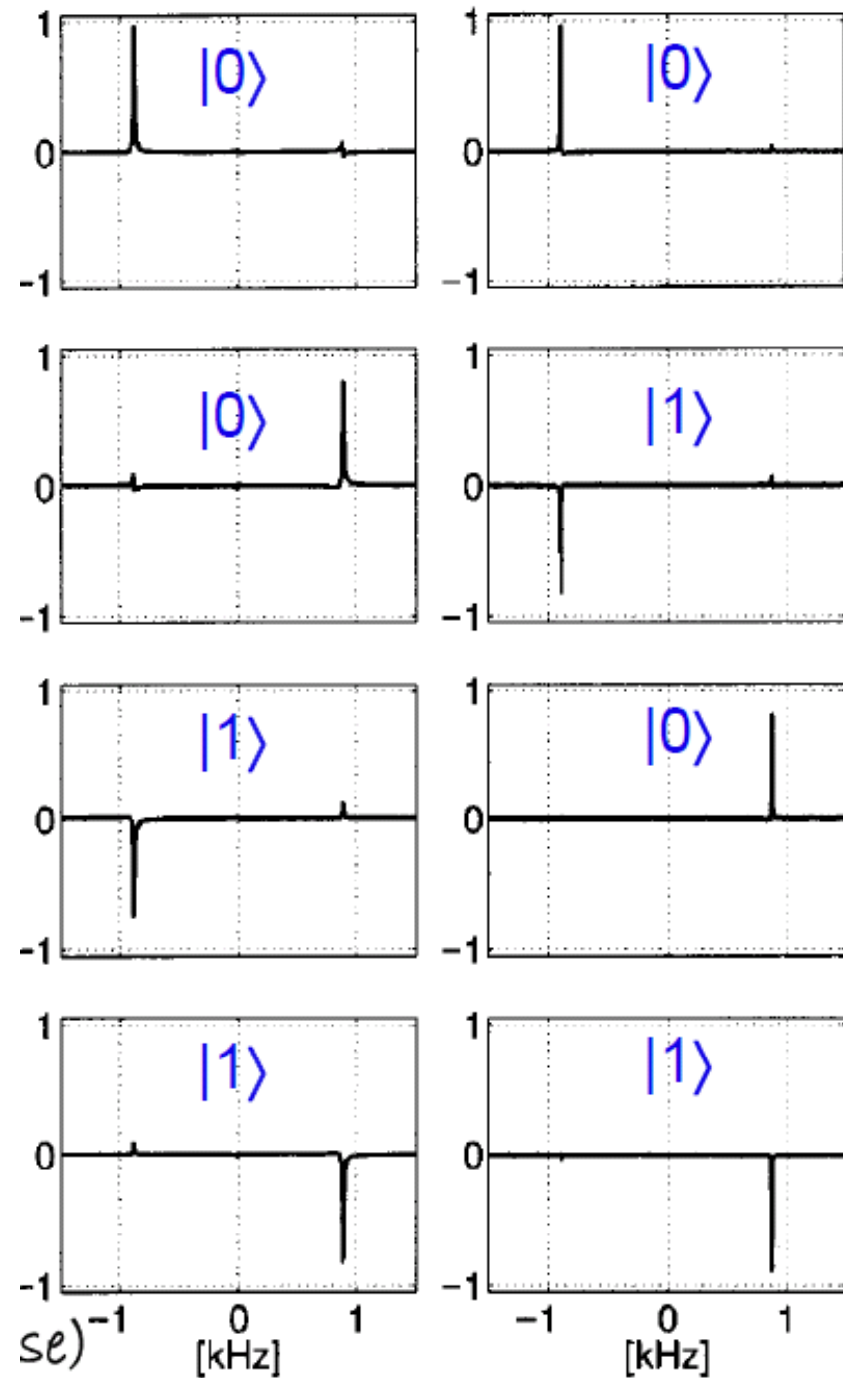

# NMR Spectrometer



Computer – Console – Superconducting magnet



Transmission /  
Receiver coil

# Liquid-state NMR

Survey of NMR quantum computing

Principles of NMR QC

➔ Techniques for qubit control

Summary: Pros & Cons

# Off-resonance pulses and spin-selectivity

$$\mathcal{H}^{rot} = -\hbar (\omega_0 - \omega_{rf}) I_z - \hbar \omega_1 \left[ \cos \phi I_x + \sin \phi I_y \right]$$

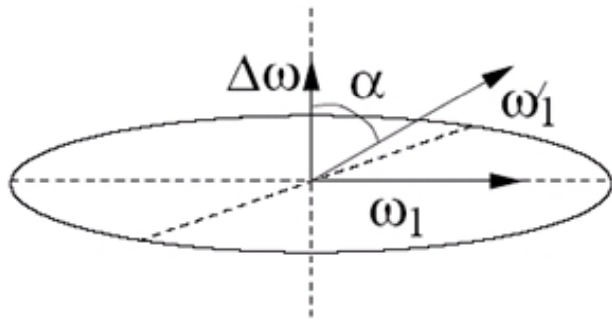

off-resonant pulses induce eff.  $\sigma_z$  rotation in addition to  $\sigma_{x,y}$

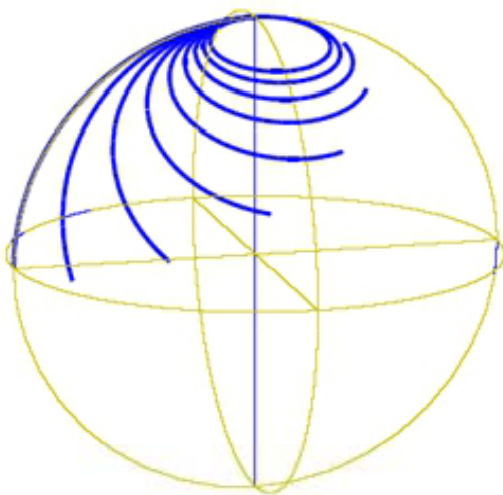

spectral content of a square pulse

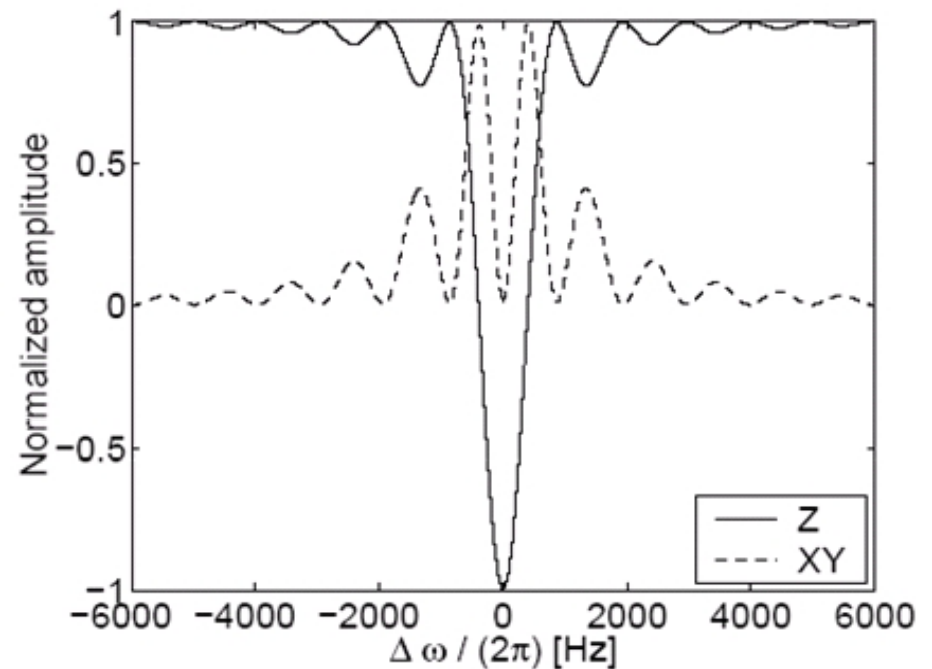

may induce transitions in other qubits

# Pulse shaping for improved spin-selectivity

gaussian pulse profile

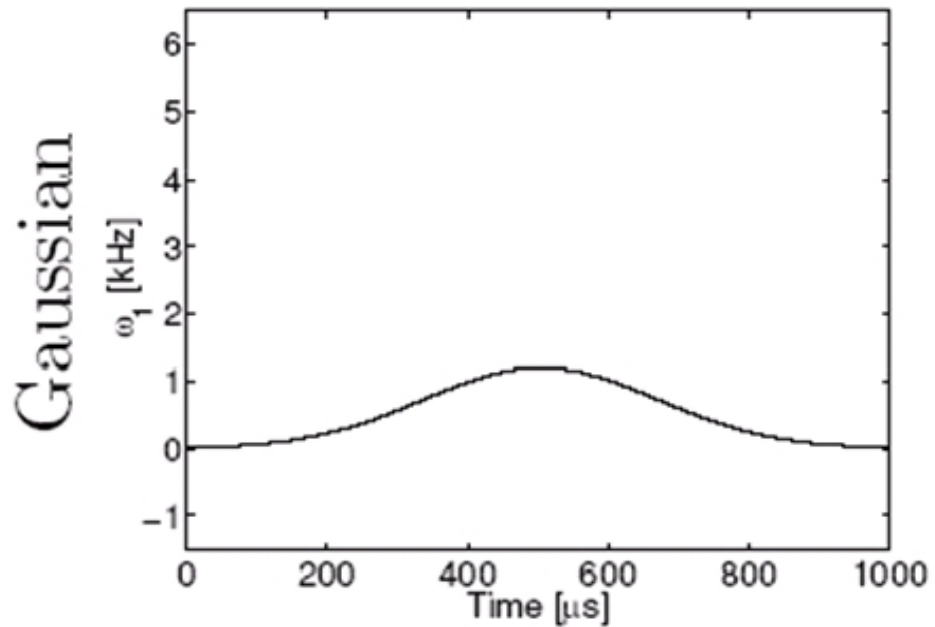

gaussian spectrum

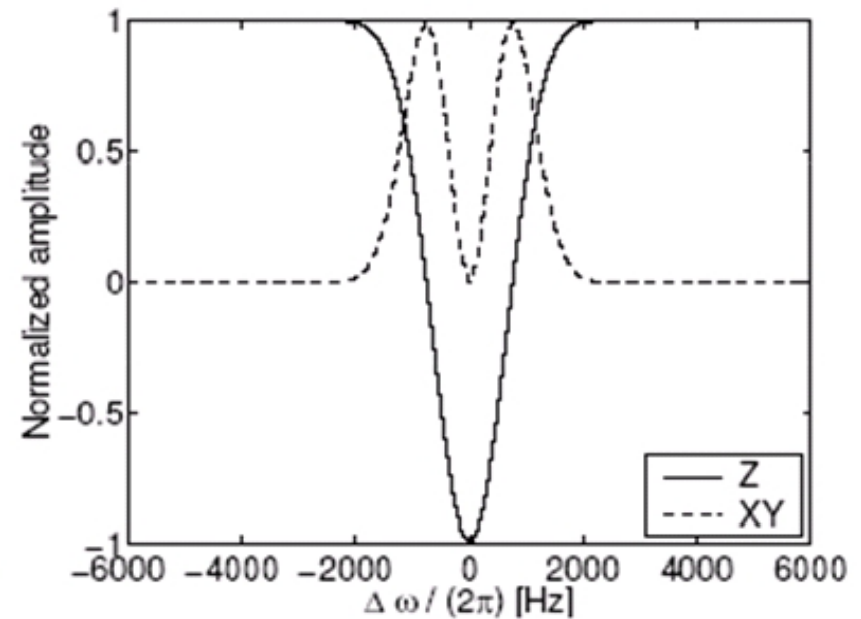

less cross-talk

# Missing coupling terms: Swap

How to couple distant qubits with only nearest neighbor physical couplings?

Missing couplings: swap states along qubit network

$$\text{SWAP}_{12} = \text{CNOT}_{12} \text{CNOT}_{21} \text{CNOT}_{12}$$

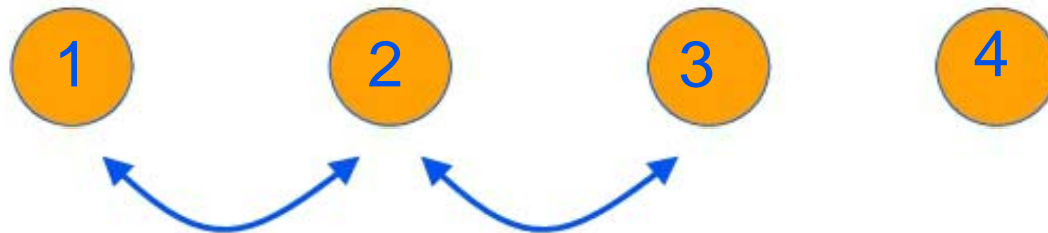

“only” a linear overhead ...

# Undesired couplings: refocus

remove effect of coupling *during delay times*

opt. 1: act on qubit B

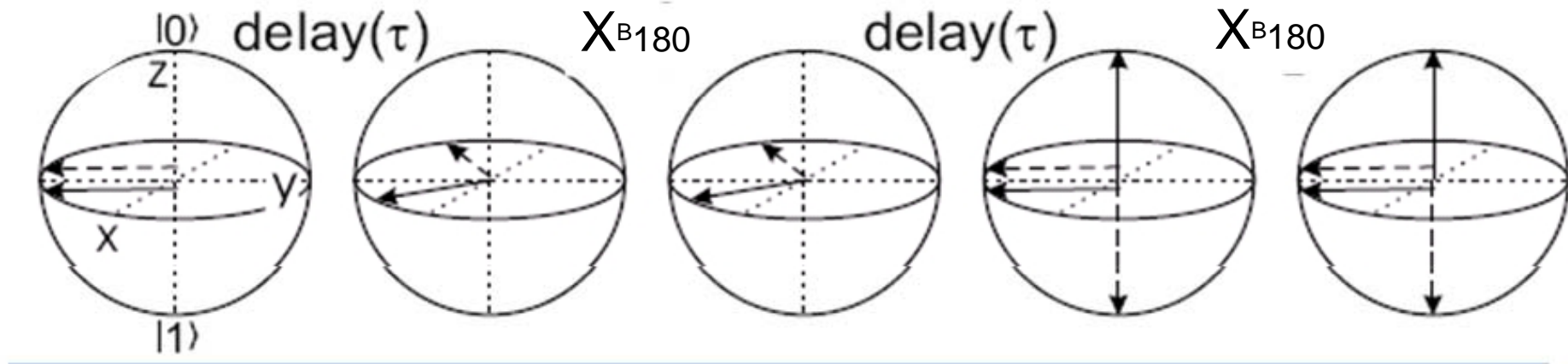

opt. 2: act on qubit A

- There exist efficient extensions for arbitrary coupling networks
- Refocusing can also be used to remove unwanted Zeeman terms



# Composite pulses

Example:  $Y_{90}X_{180}Y_{90}$

corrects for  
under/over-rotation

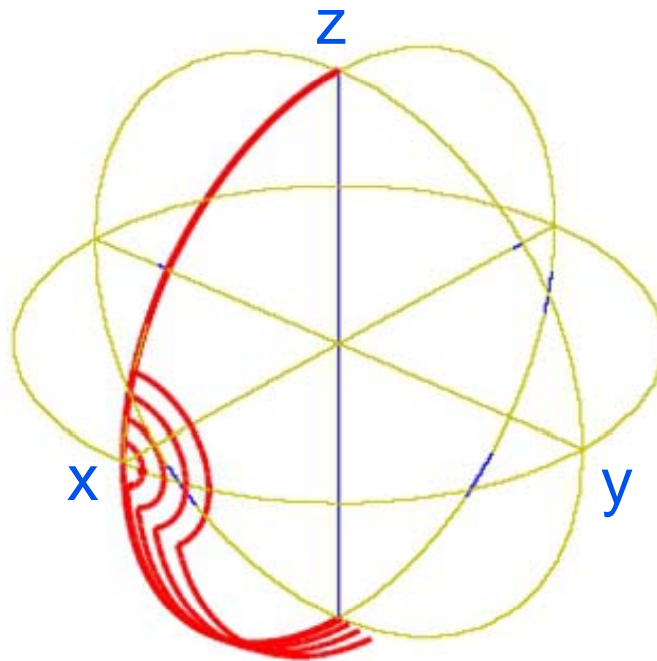

corrects for  
off-resonance

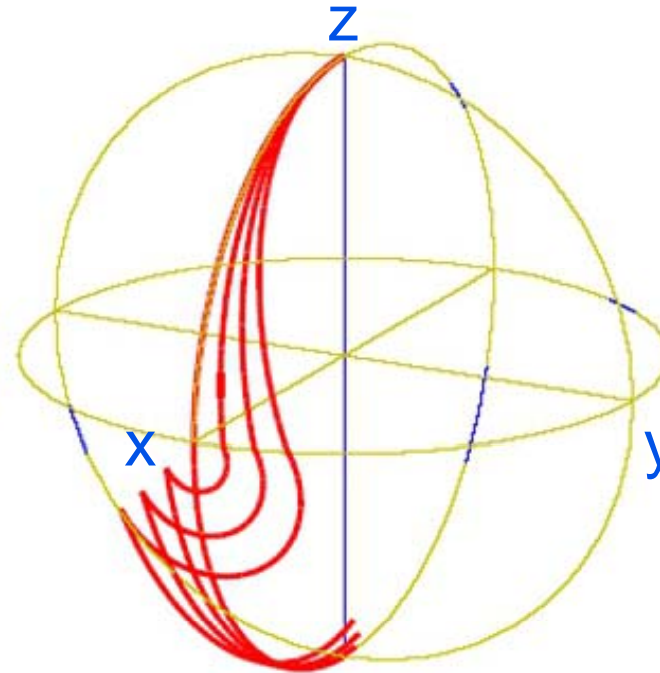

However: doesn't work for arbitrary input state  
But: there exist composite pulses that work for all input states



# Molecule selection

A quantum computer is a *known* molecule.

Its desired properties are:

- spins 1/2 ( $^1\text{H}$ ,  $^{13}\text{C}$ ,  $^{19}\text{F}$ ,  $^{15}\text{N}$ , ...)
- long  $T_1$ 's and  $T_2$ 's
- heteronuclear, or large chemical shifts
- good J-coupling network (clock-speed)
  
- stable, available, soluble, ...



required to make  
spins of same  
type addressable

# Quantum computer molecules (1)

red nuclei are used  
as qubits:

Grover / Deutsch-Jozsa

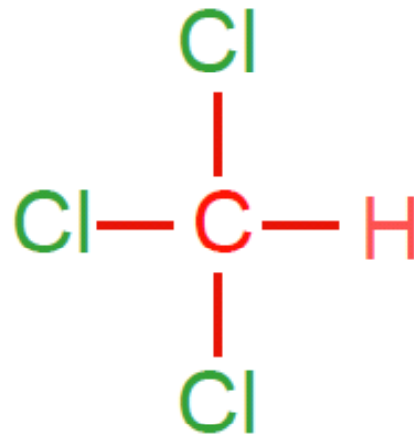

Q. Error correction

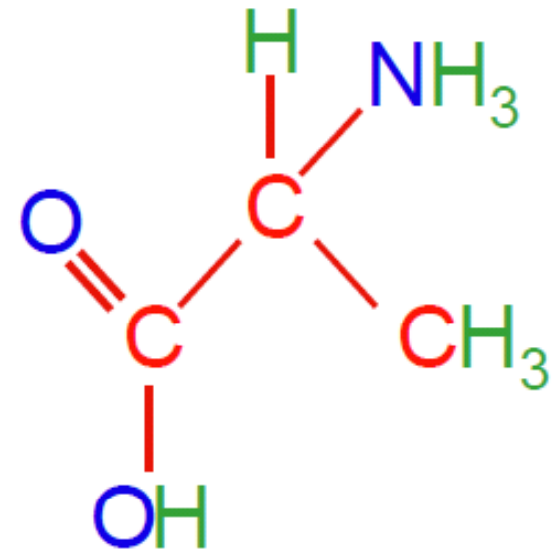

Logical labeling / Grover

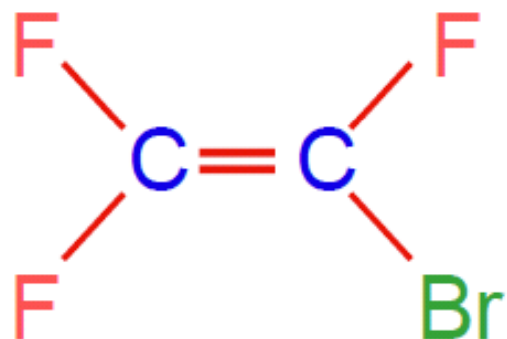

Teleportation

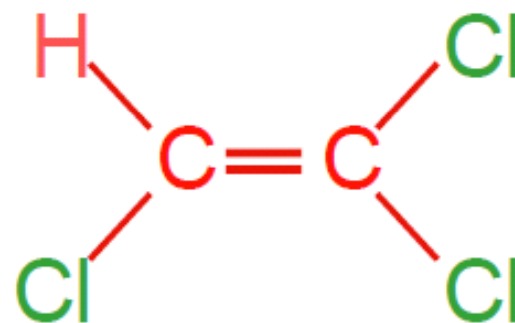

Q. Error Detection

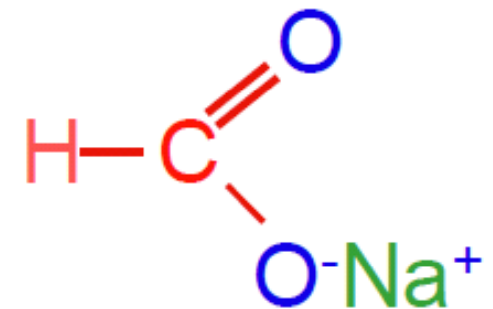

# Quantum computer molecules (2)

Deutsch-Jozsa

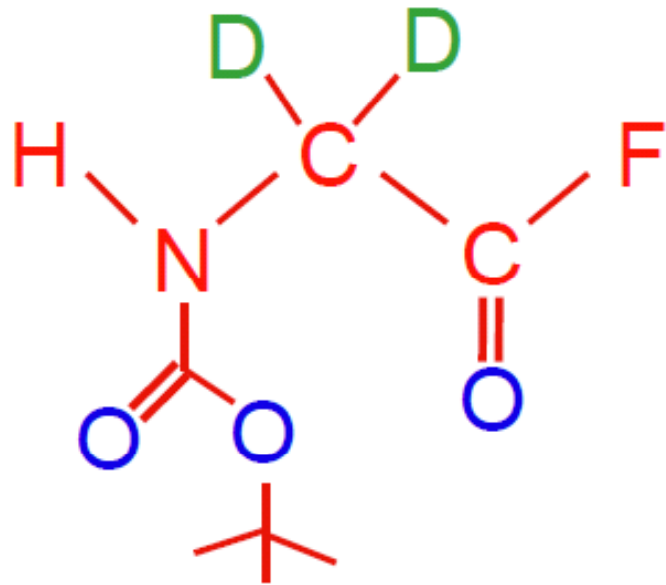

7-spin coherence

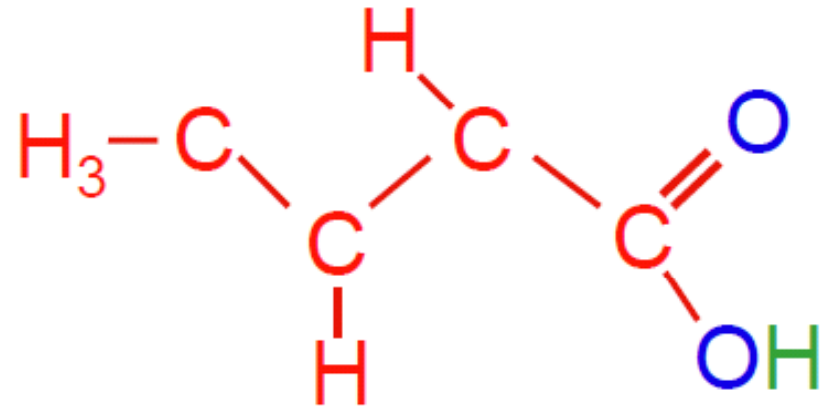

Order-finding

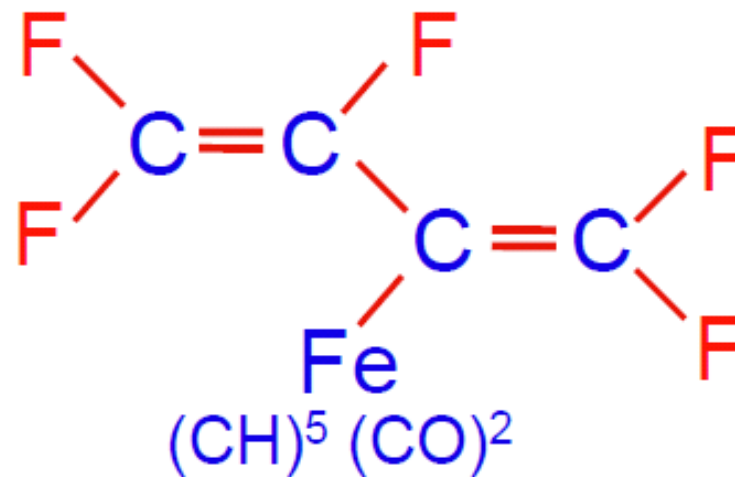

# Liquid-state NMR

Survey of NMR quantum computing

Principles of NMR QC

Techniques for qubit control

➔ Summary: Pros & Cons

# The good news

- Quantum computations have been demonstrated in the lab
- A high degree of control was reached, permitting hundreds of operations in sequence
- A variety of tools were developed for accurate unitary control over multiple coupled qubits
  - ⇒ *useful in other quantum computer realizations*
- Spins are natural, attractive qubits

# The main issue: Scaling

**We do not know how to scale liquid NMR QC**

Main obstacles:

- Signal after initialization  $\sim 1 / 2^n$  [at least in practice]
- Coherence time typically goes down with molecule size
- We have not yet reached the accuracy threshold ...

# Main sources of errors in NMR QC

Early on (heteronuclear molecules)

inhomogeneity RF field

Later (homonuclear molecules)

$J$  coupling during RF pulses

Finally

decoherence

# Electron spin qubits

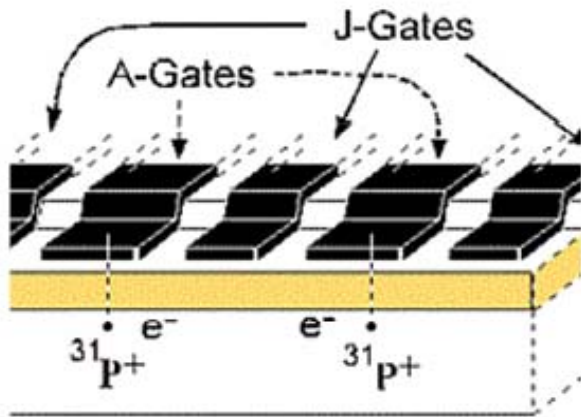

Kane, Nature 1998

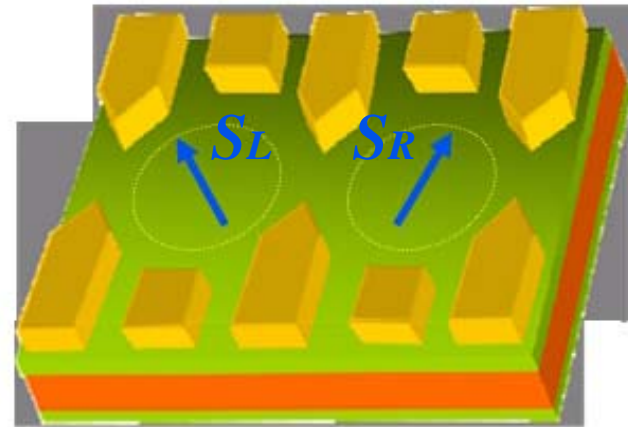

Loss & DiVincenzo, PRA 1998

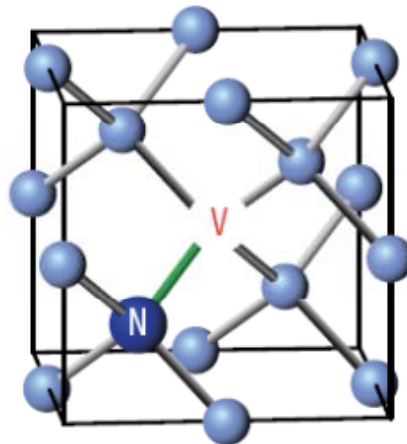

Gruber, Science, 1997





# Quantum information using single spins in diamond

Literature hint:

F. Jelezko, J. Wrachtrup,  
"Single defect centres in diamond: A review"  
Phys. stat. sol. (a) 203, 3207 (2006).

# Single spins in diamond



Diamond nitrogen vacancy center (NV Center)

- Principles of Optically-detected magnetic resonance (ODMR)
- Initialization, manipulation, read-out of NV electron spin

Environment: Diamond host material

Applications

# Optically-detected magnetic resonance (ODMR)

Idea: Detect optical instead of microwave/radio-frequency photons

Requirement: Optical photon must be correlated with spin state

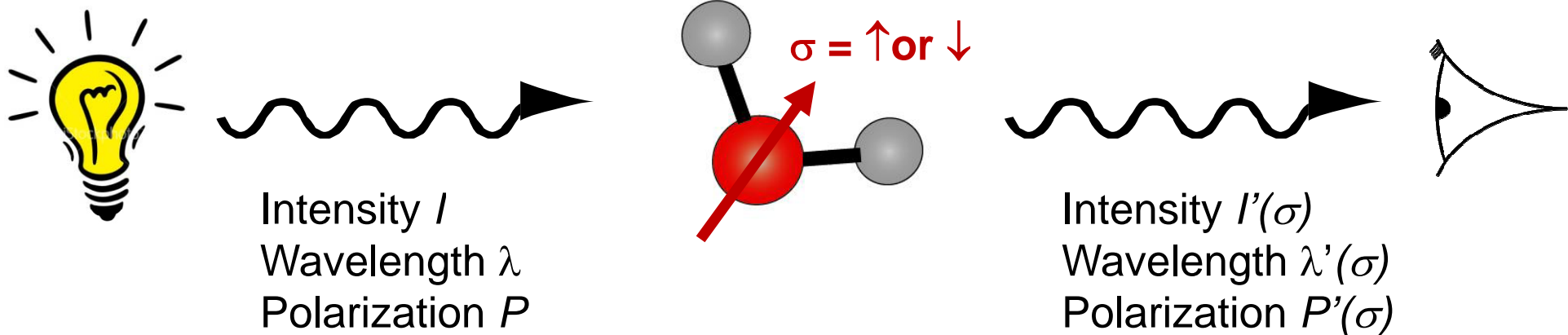

# Optically detected magnetic resonance

## Some History

- Optical detection of paramagnetism in phenantren (Kwiram, 1967)

(... 1980ies: Invention of single molecule spectroscopy ...)

- Optical detection of magnetic resonance in a single pentacene molecule  
Wrachrup, Moerner (1993)

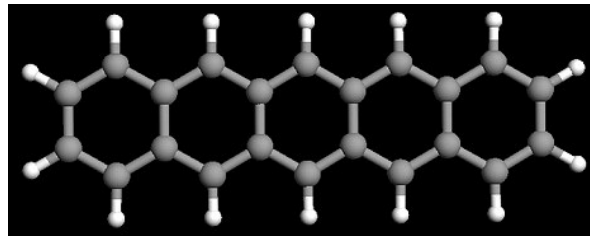

- Optical detection of single nitrogen vacancy centers in diamond:  
Gruber, Wrachtrup (1997)

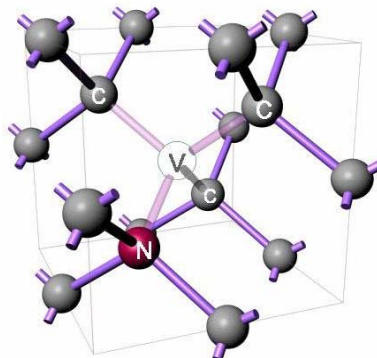

# Single spin detection of NV centers

Gruber, Science 1997

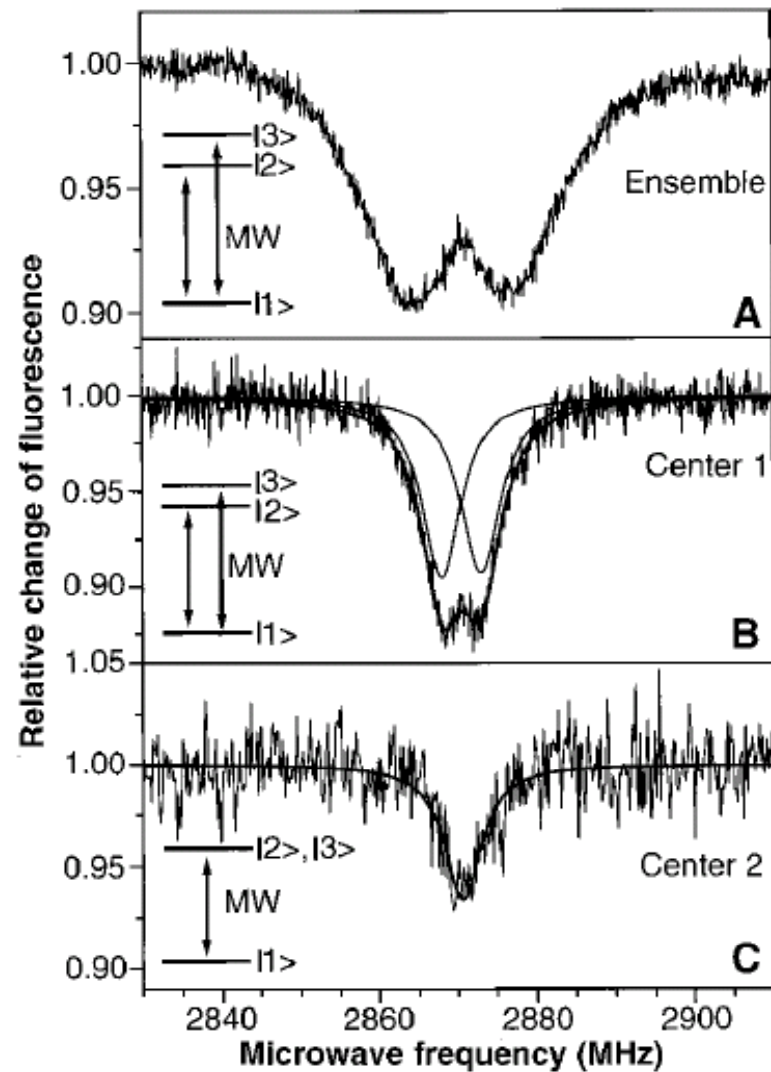
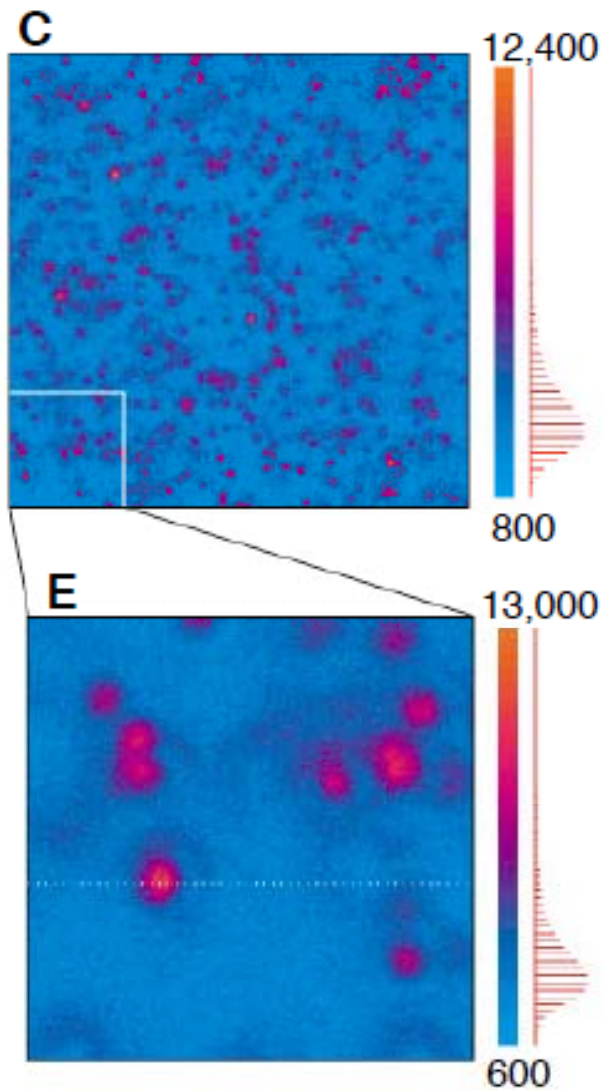

# Readout and Polarization of the NV center

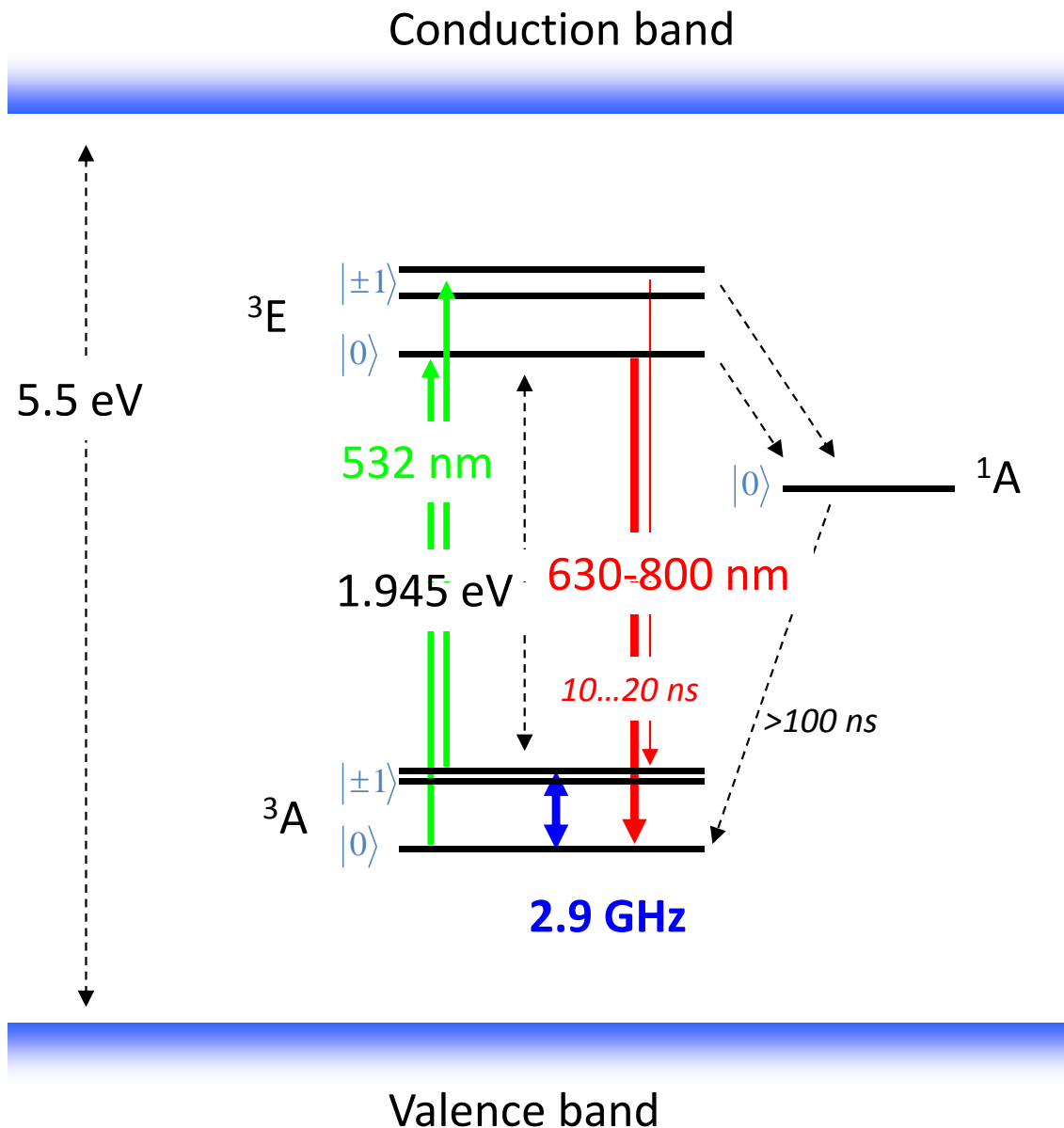

## Readout:

- $m_s = 0$  scatters 30% more light than  $m_s = \pm 1$
- Many readout cycles needed to detect spin state

## Polarization (“Reset”):

- Illumination pumps spin into  $m_s = 0$  state (>90% fidelity)

# Spin Hamiltonian

$$\mathcal{H} = D\left(S_z^2 - \frac{1}{3}S^2\right) + \beta_e \mathbf{B} \bar{g}_e \mathbf{S} + \mathbf{S} \bar{\mathbf{A}} \mathbf{I}$$

Zero field splitting  
(2.87 GHz)

Electron Zeeman  
(2.8 MHz/Gauss)

Hyperfine coupling to  $^{14}\text{N}$   
(~2.2 MHz)

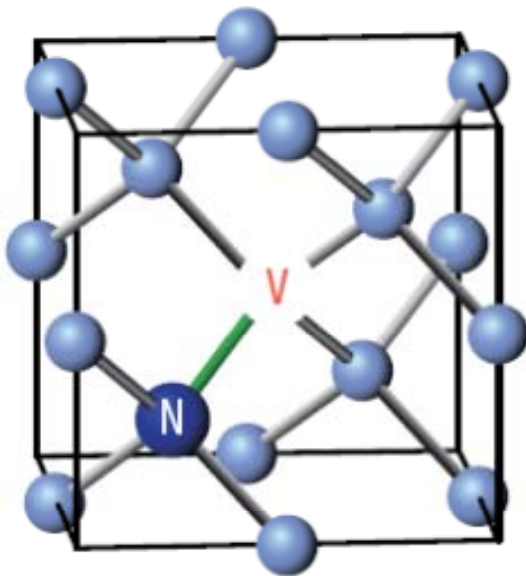

# Spin Hamiltonian

$$\mathcal{H} = D\left(S_z^2 - \frac{1}{3}S^2\right) + \beta_e B \bar{g}_e \bar{S} + \bar{S} \bar{A} \bar{I}$$

Zeeman

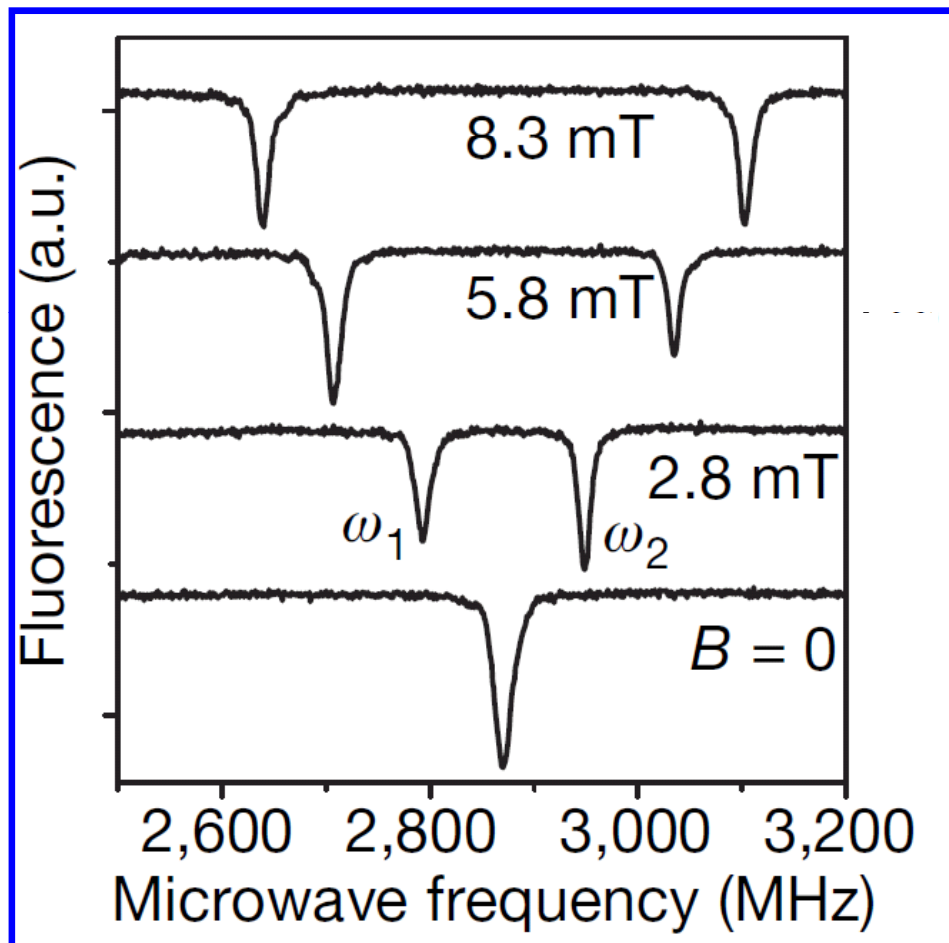

Hyperfine

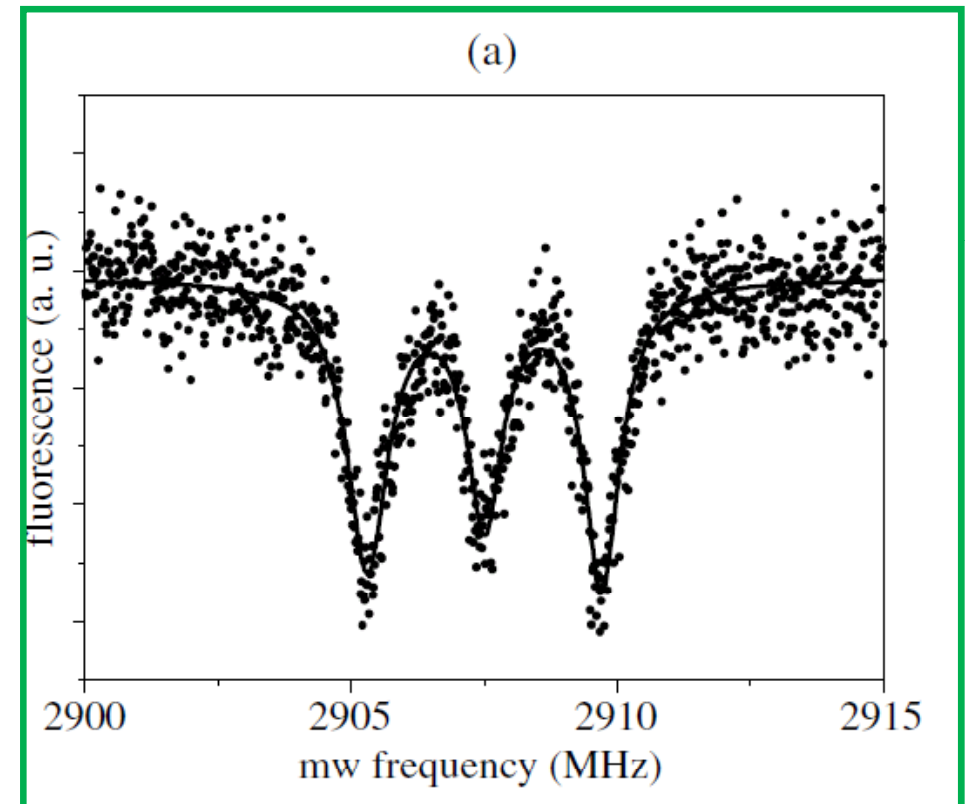



# NV centers in diamond

## Some properties:

- Single photon emitter
- Optically stable:  
No bleaching, no blinking
- High quantum yield ~70%
- Room temperature
- Long spin coherence times >1ms
- In nanodiamonds down to 5 nm
- Excellent chemical stability
- Non-toxic biomarkers
- Inexpensive!
- ...

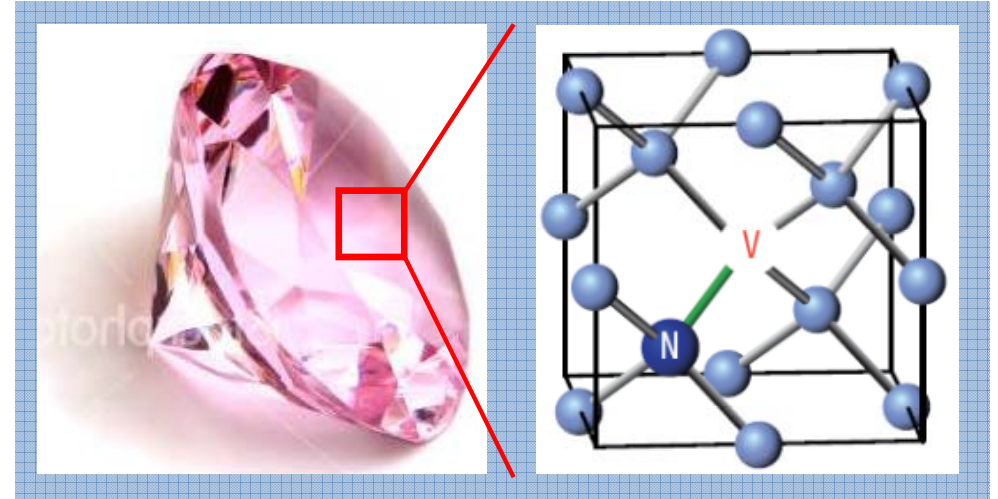

Nitrogen Vacancy defect in diamond

# Fabrication – Ion implantation

NV centers implanted into single crystal diamond, then patterned with waveguide

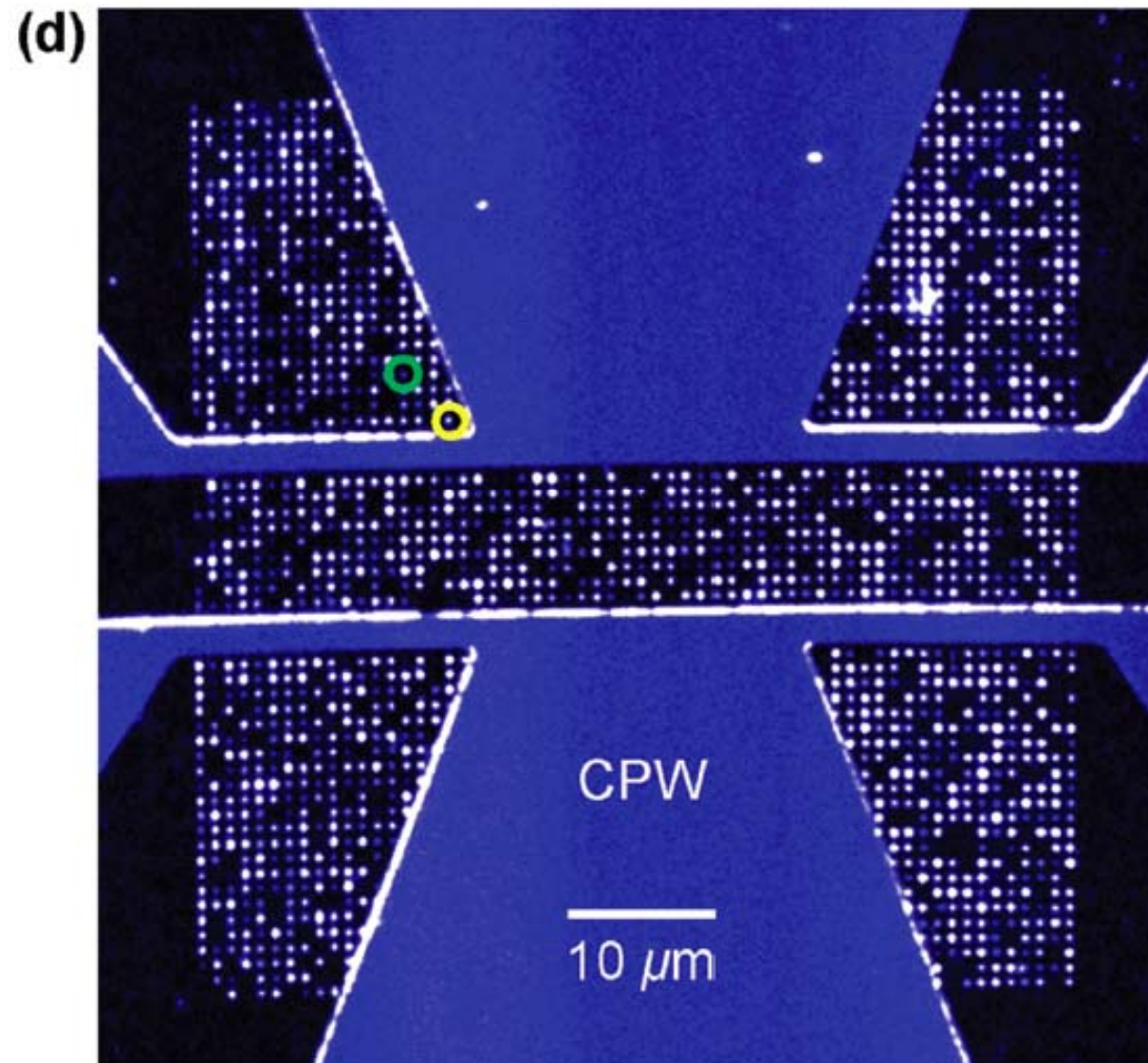
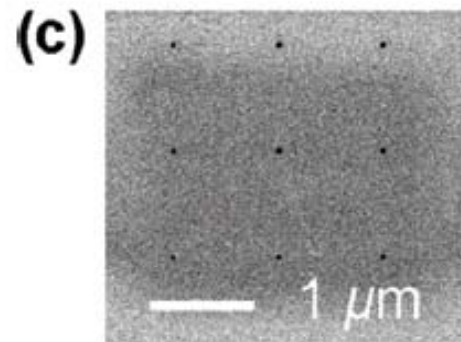
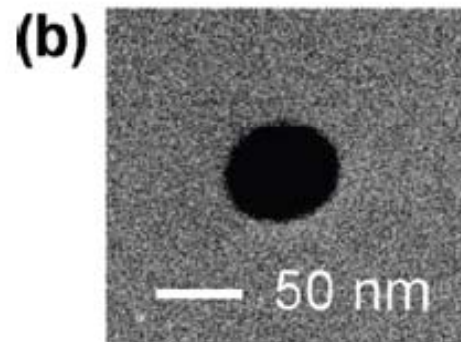
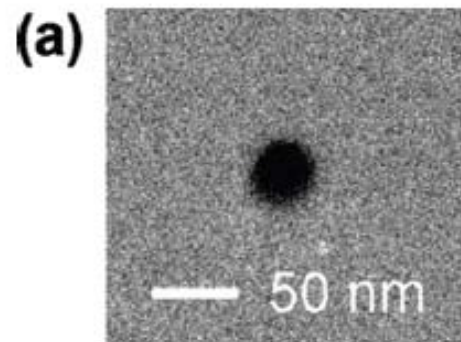

# Rapid spin manipulation by waveguides

## Rabi Oscillations

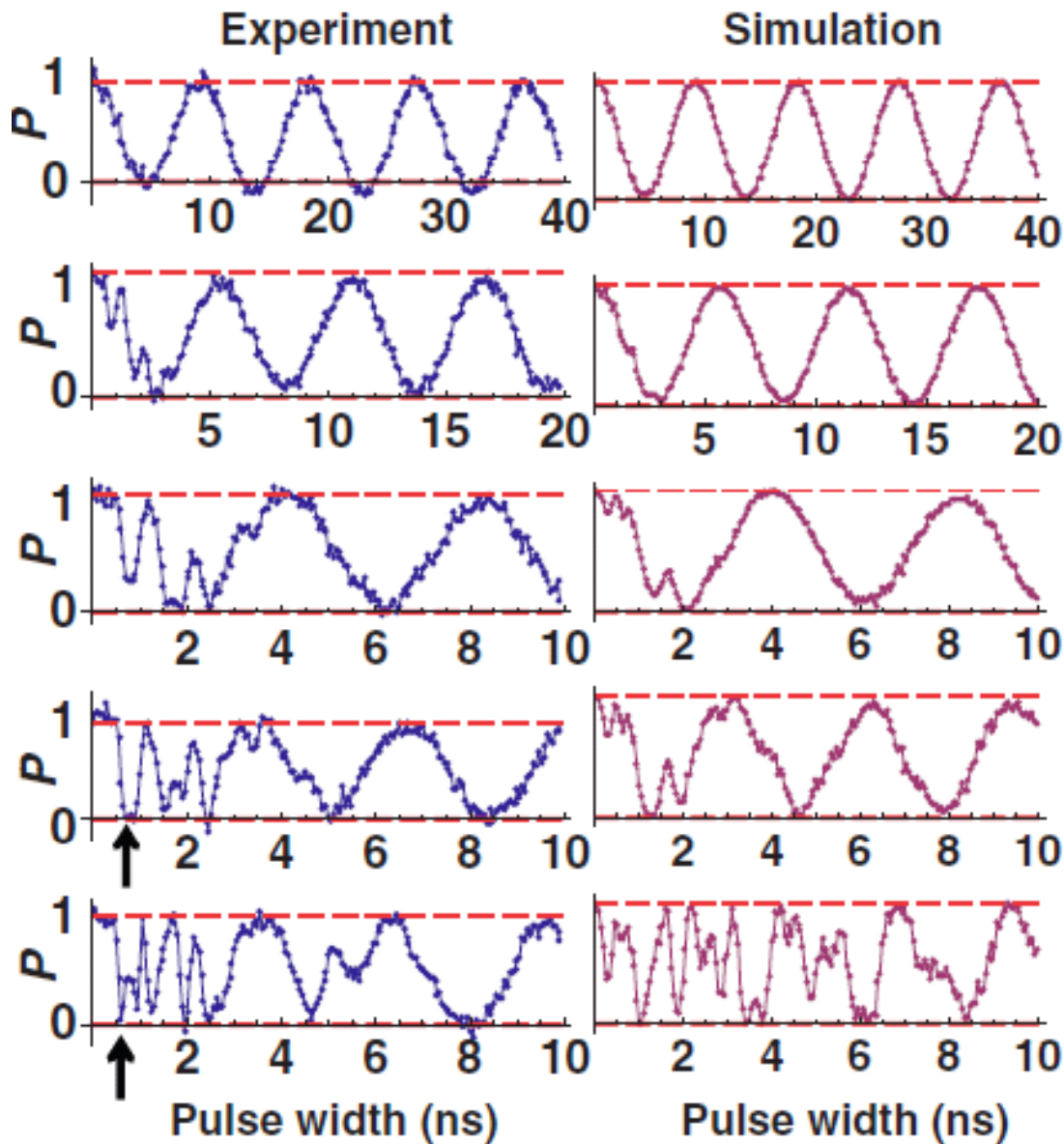

➔ Spin inversion within ~ 1 ns

# Single spins in diamond

Diamond nitrogen vacancy center (NV Center)

- Principles of Optically-detected magnetic resonance (ODMR)
- Initialization, manipulation, read-out of NV electron spin



Environment: Diamond host material

Applications

# Spin environment

## Nuclear spins

- $^{14}\text{N}$  NV nuclear spin ( $I=1$ )
- $^{13}\text{C}$  spins ( $I=1/2$ )  
*1.03% natural abundance*
  - First shell: 3x dangling bonds
  - Second, third, ... shell
  - Distant: “Classical” spin bath
- ...
- Surface spins (adsorbates)

## Electron spins

- Nearby **N defect** electron spins ( $S=1/2$ ) (“ $P_1$  or C centers”)
- Nearby other **NV center** ( $S=1$ )
- ...
- Surface spins (electronic, nuclear)

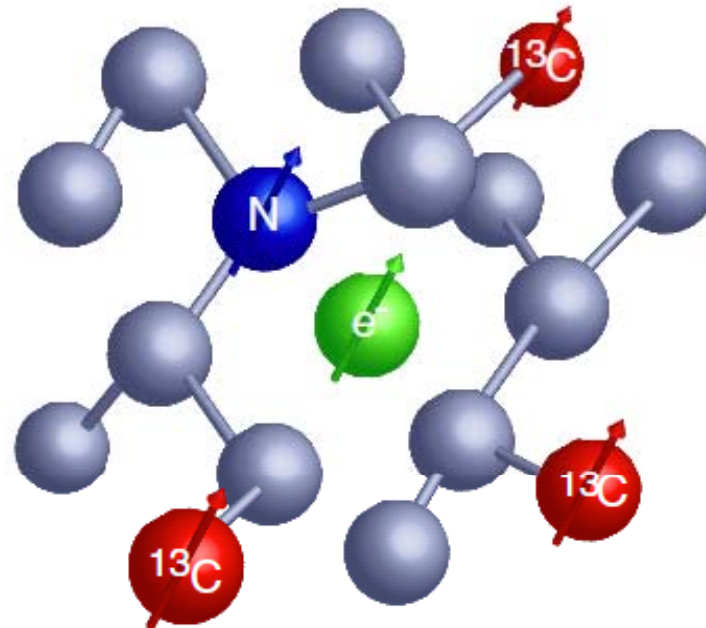



# Other electronic spins

Nearby N defect with  $S = \frac{1}{2}$  ("P1 center")

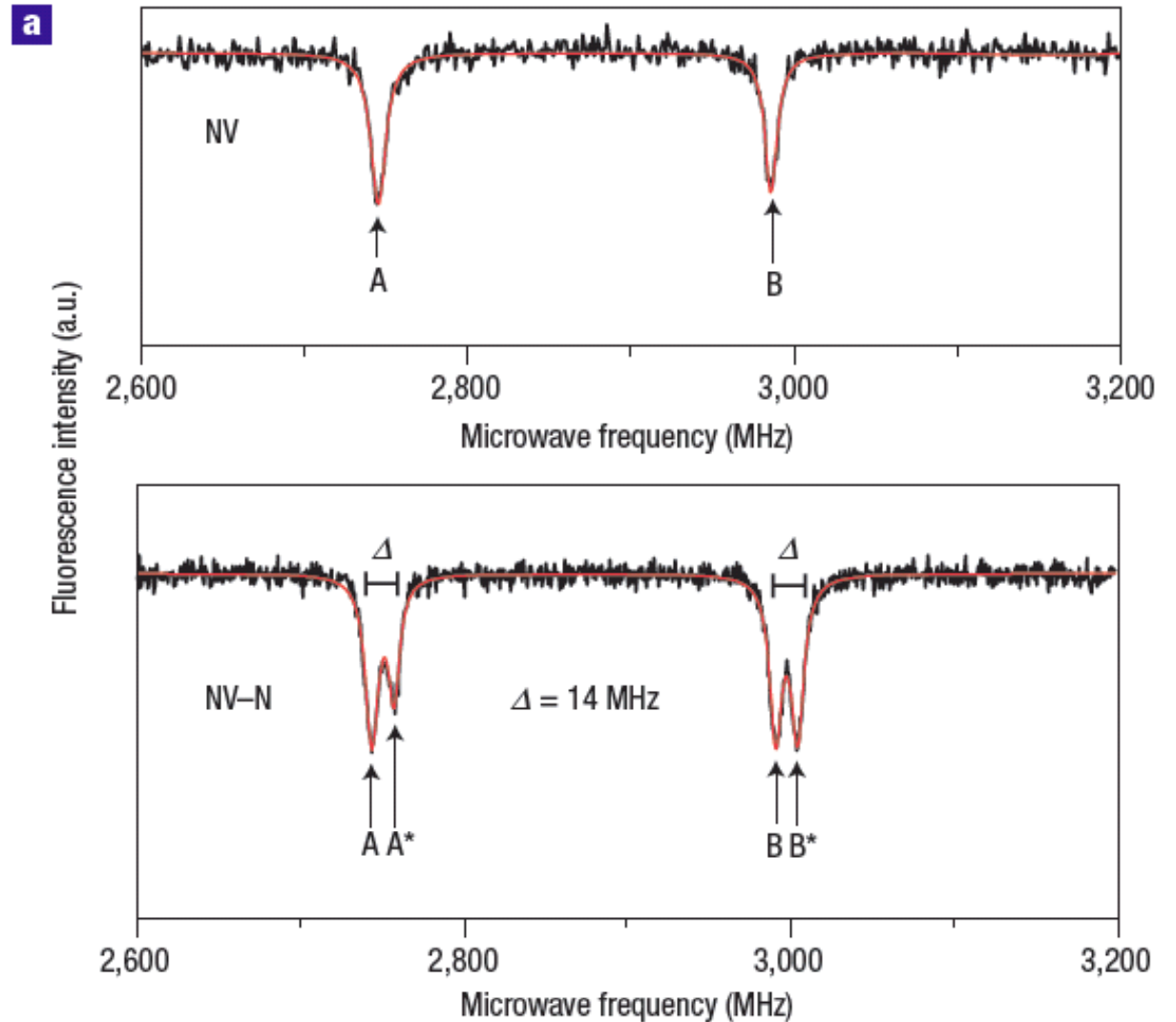
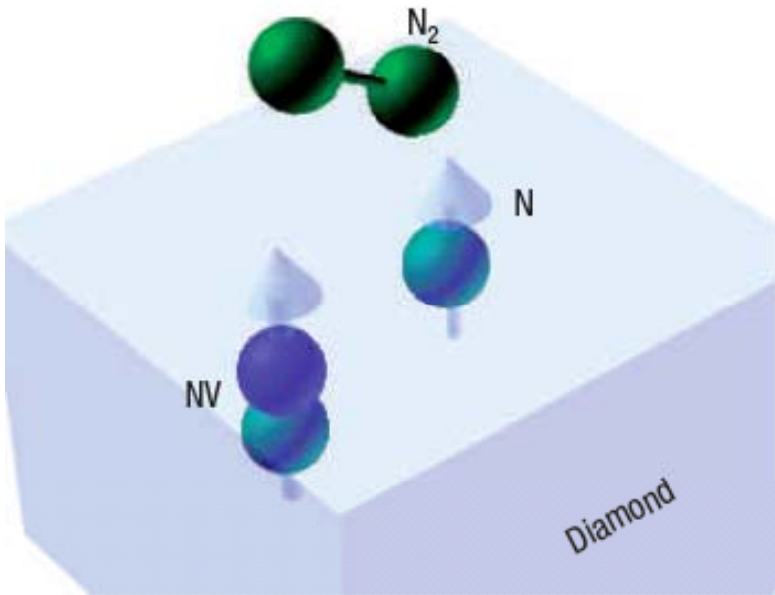

# Coupling between two NV centers

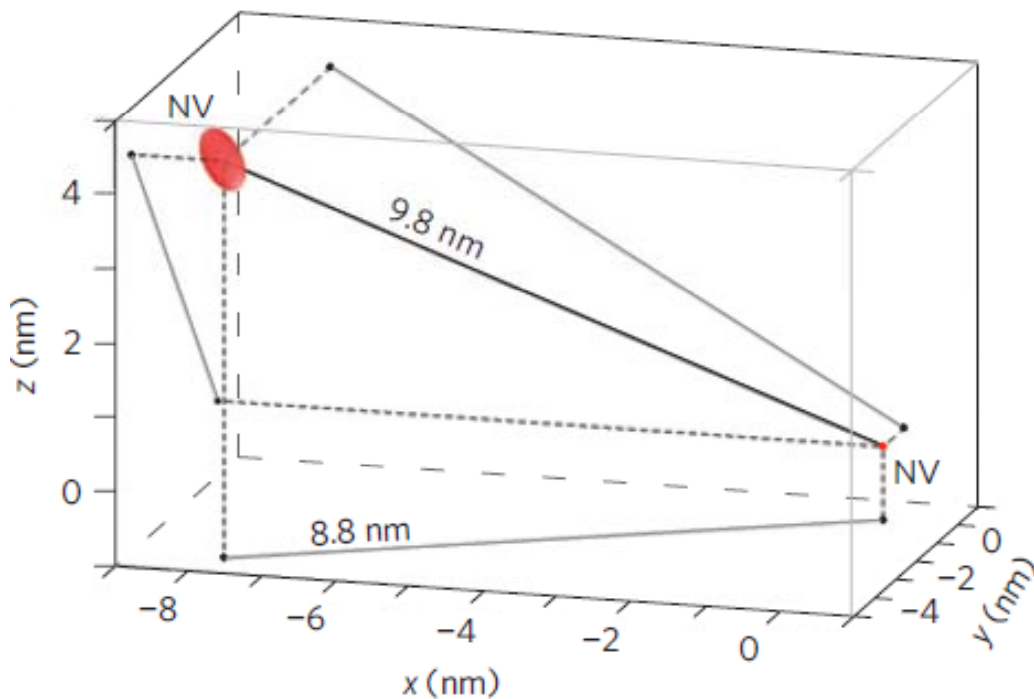
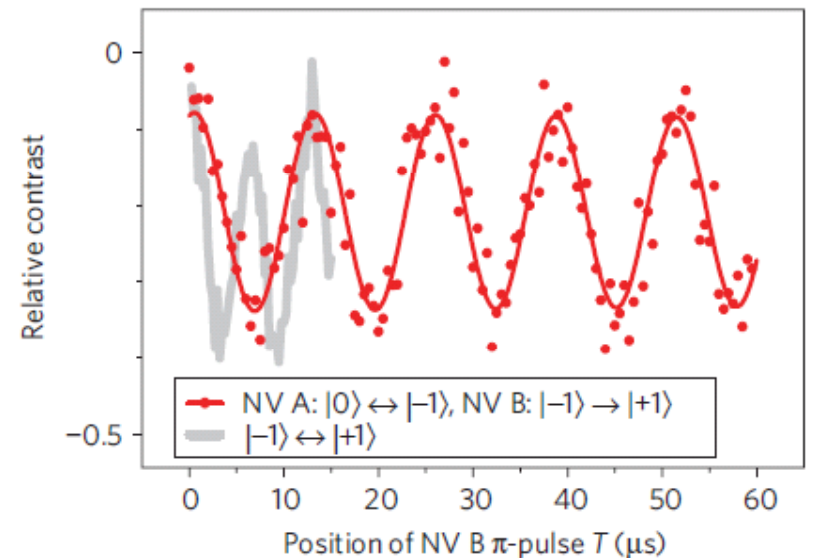
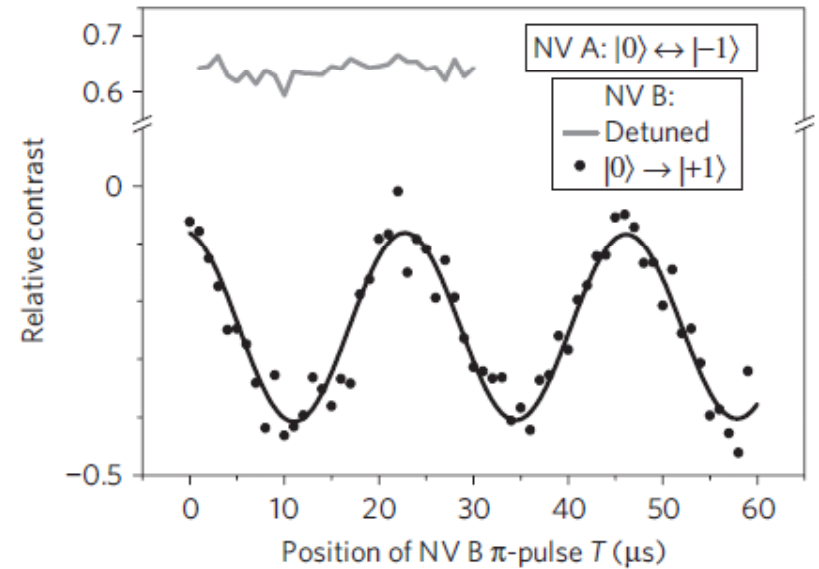
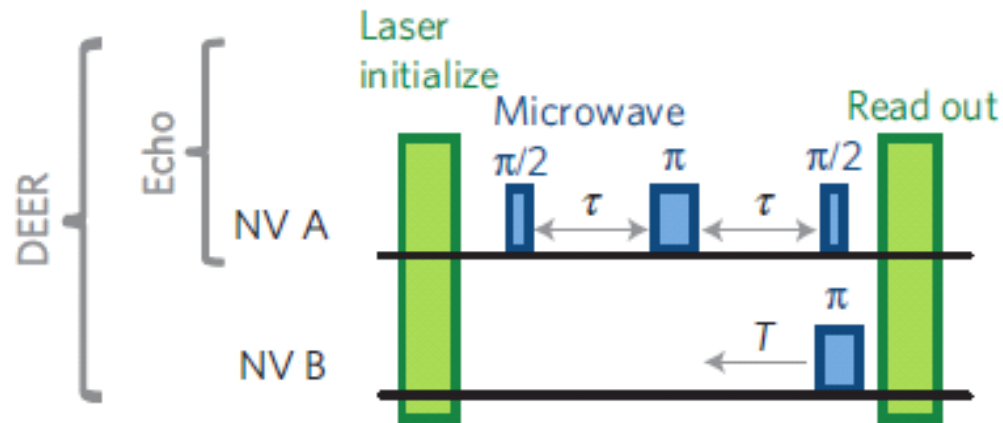

# The $^{13}\text{C}$ nuclear spin environment

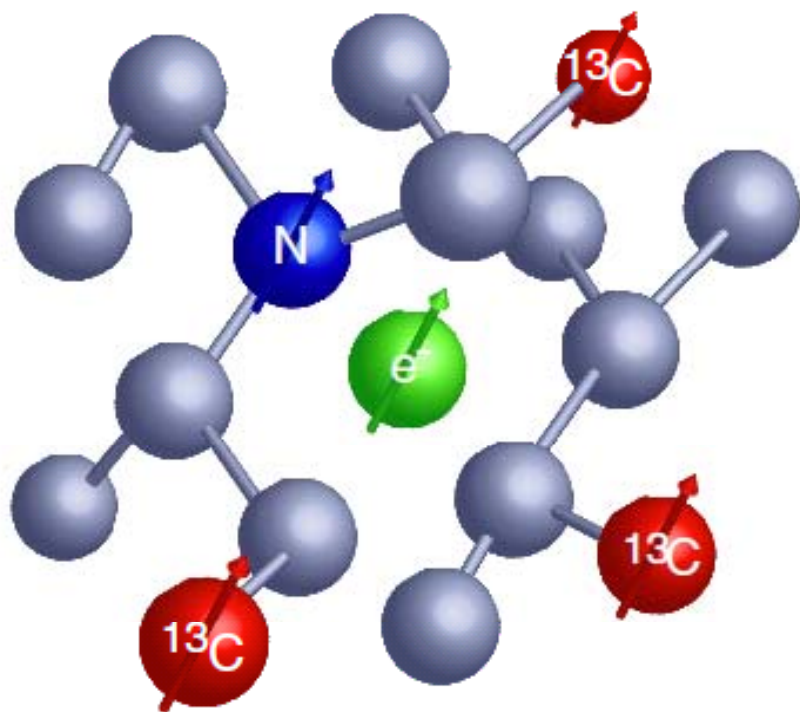

**Near  $^{13}\text{C}$  spins** – resolved lines

**Intermediate  $^{13}\text{C}$  spins** – lines not resolved, but still moderate hyperfine coupling

**Distant  $^{13}\text{C}$  spins** – very weak hyperfine coupling (“classical ensemble”)



# Specific nearby $^{13}\text{C}$

## Two qubits: NV + $^{13}\text{C}$

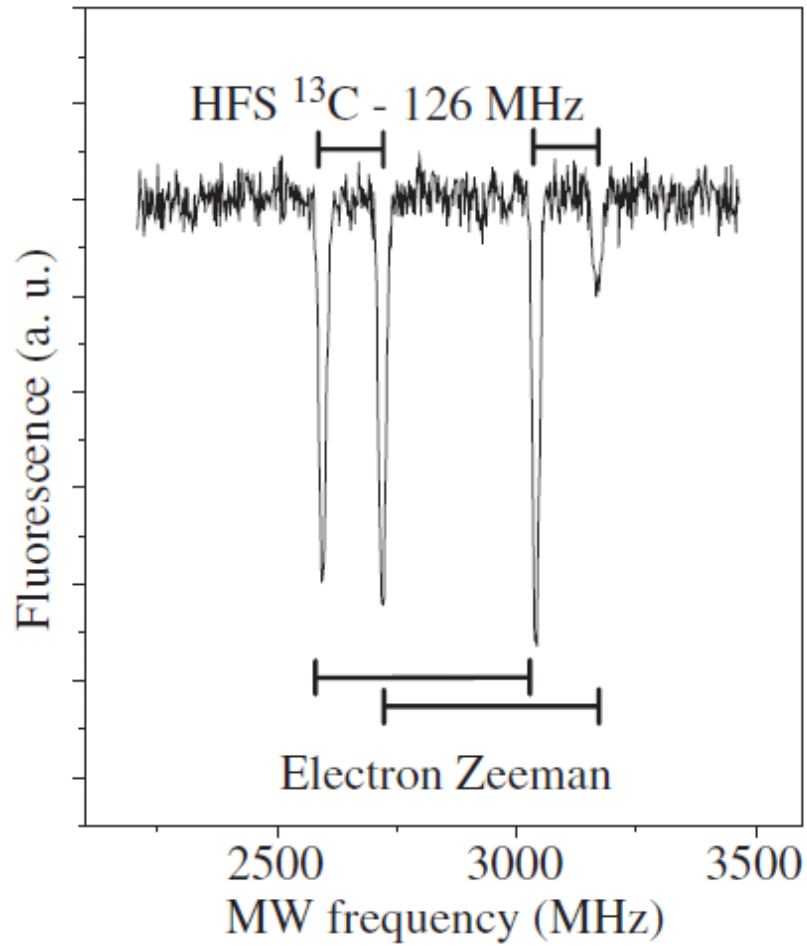

## Three qubits: NV + $^{13}\text{C}$ + $^{13}\text{C}$

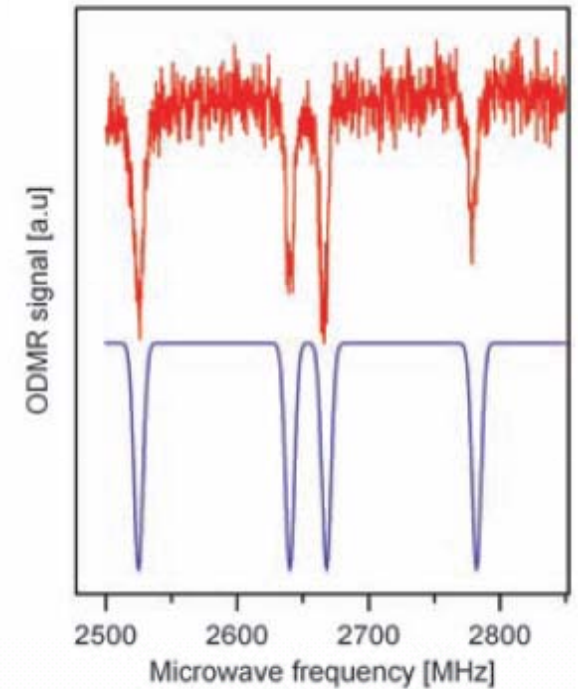

# Repetitive readout

Store and Readout NV spin state in nearby  $^{13}\text{C}$  nucleus

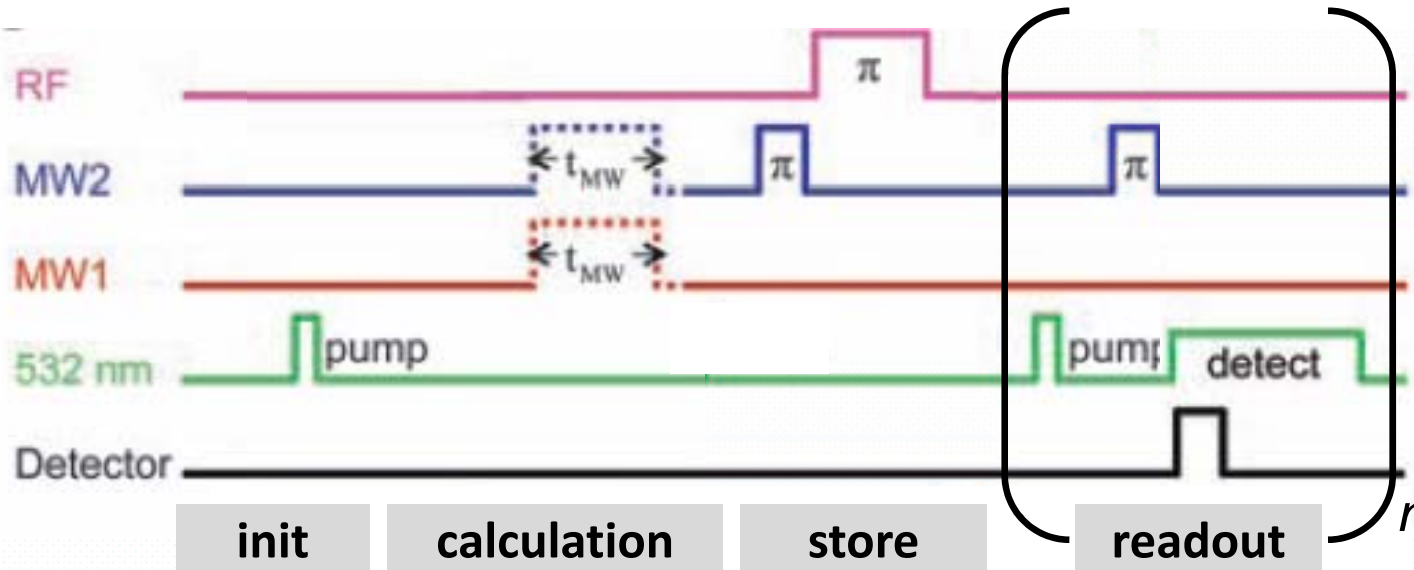

Example:  
Rabi oscillation

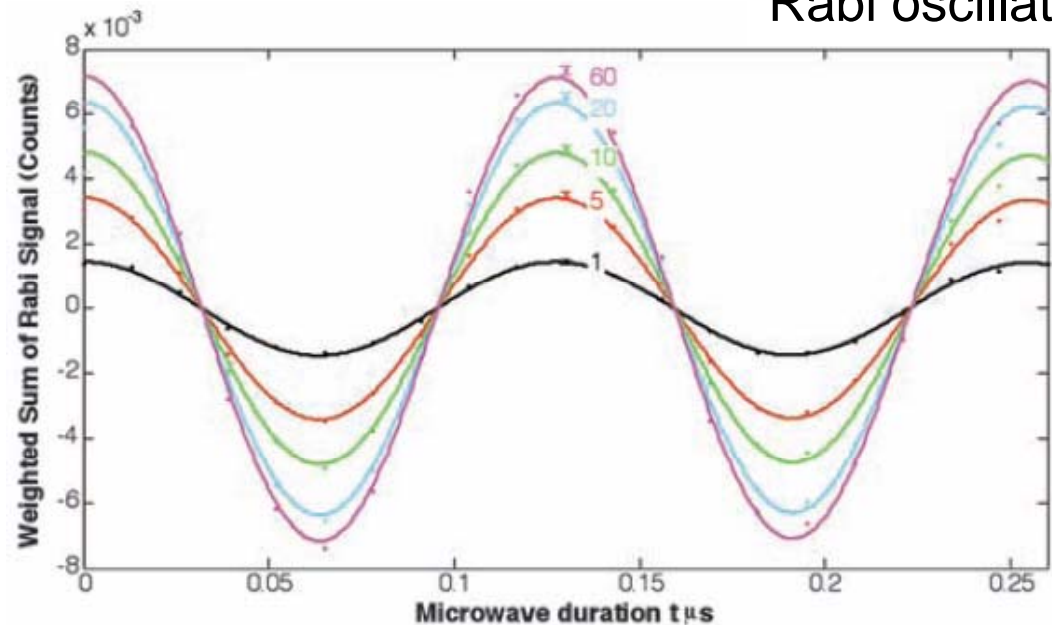
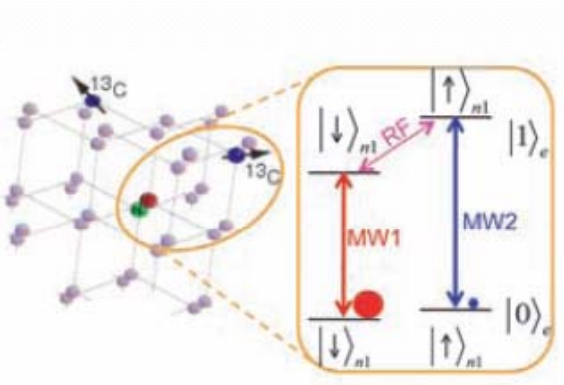

# Distant $^{13}\text{C}$ spin bath

Periodic “revivals” of spin echo with  $^{13}\text{C}$  Larmor frequency

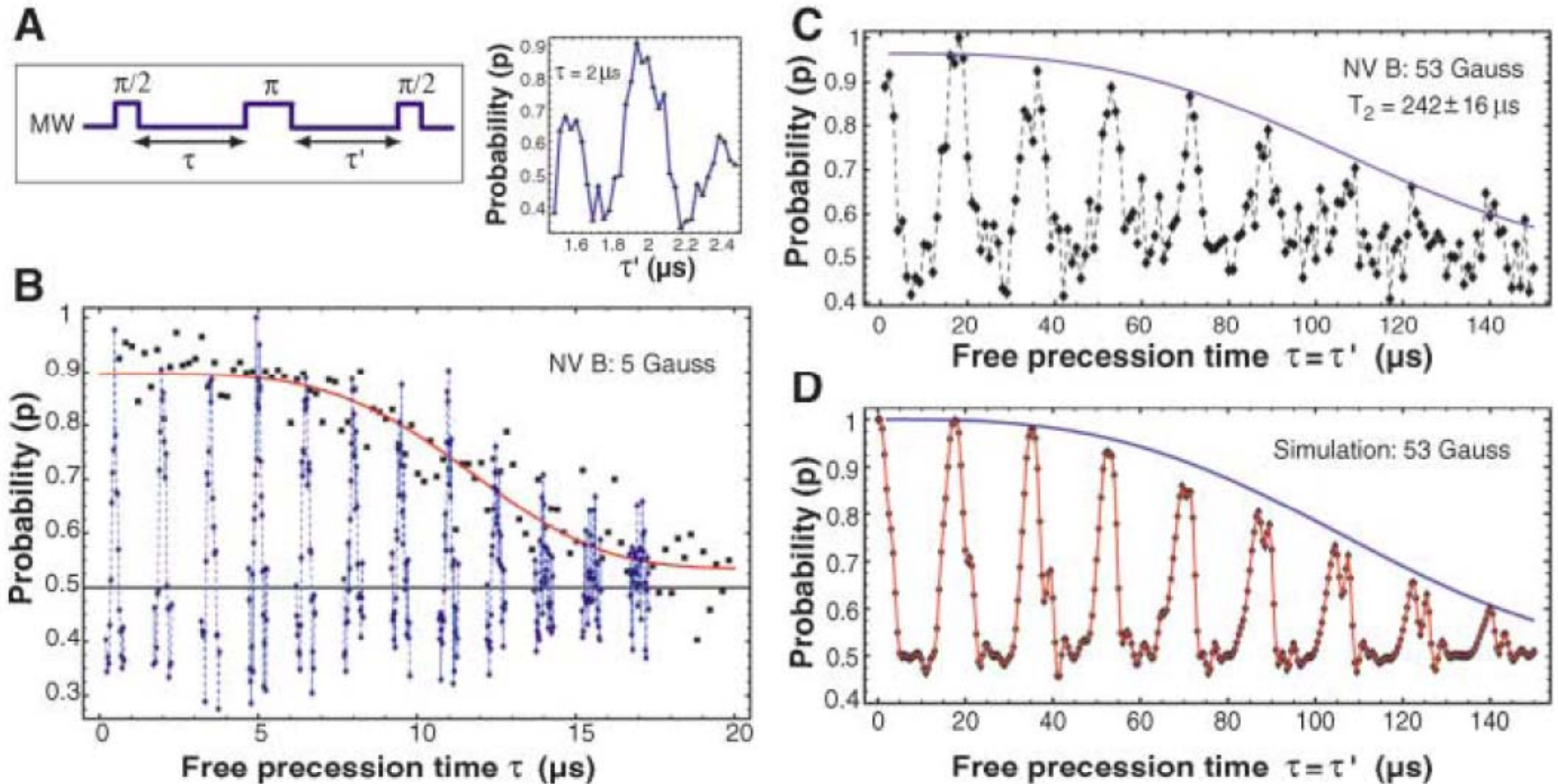

# Eliminating $^{13}\text{C}$ nuclear spin bath

## The materials scientists' way ...

$^{13}\text{C}$ content	Spin coherence time $T_2$
20.7%	0.010 ms
8.4 %	0.12 ms
1.1 % (natural)	0.65 ms
0.4%	1.8 ms

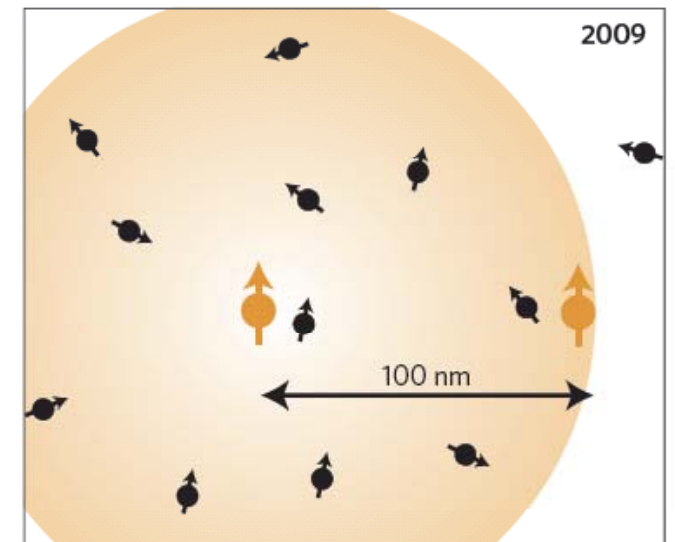
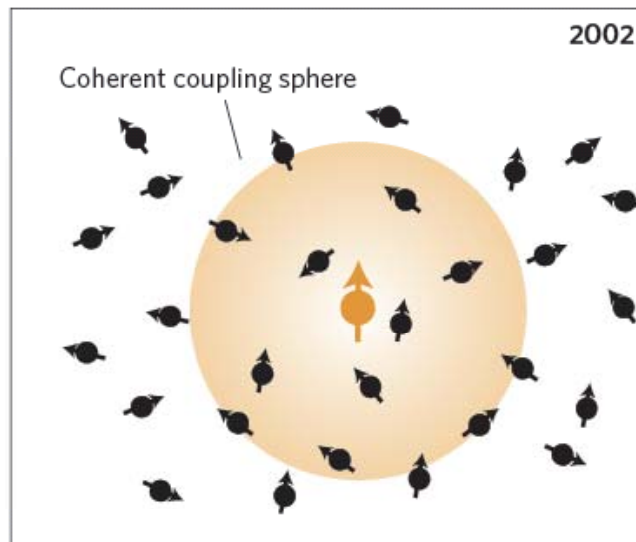
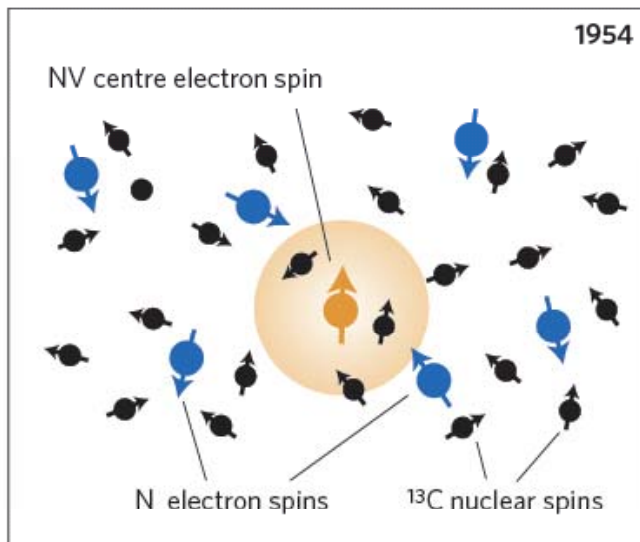

# Eliminating $^{13}\text{C}$ nuclear spin bath

... the spectroscopists way

Multi-pulse decoupling  
(also “dynamical decoupling”)

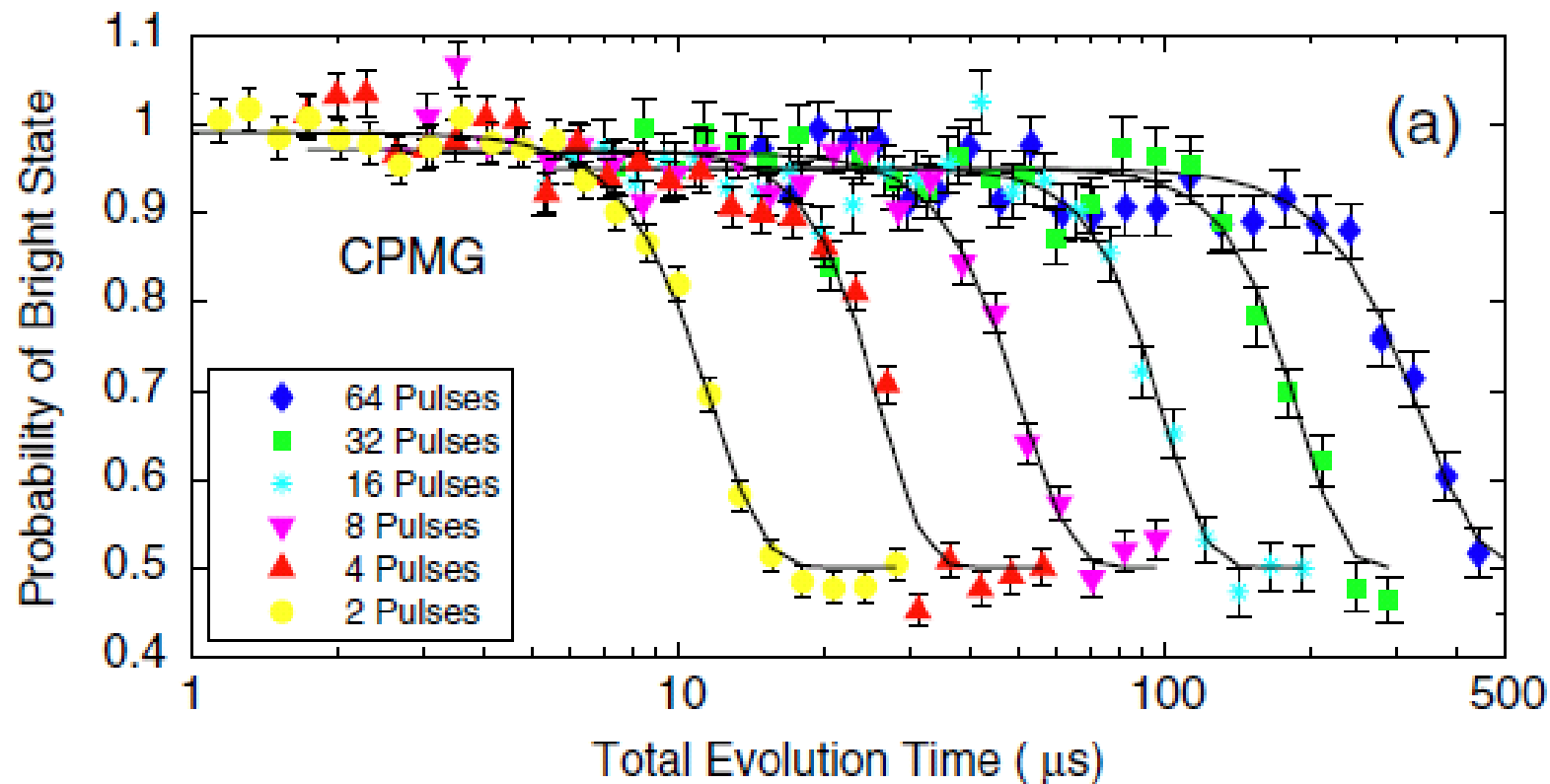
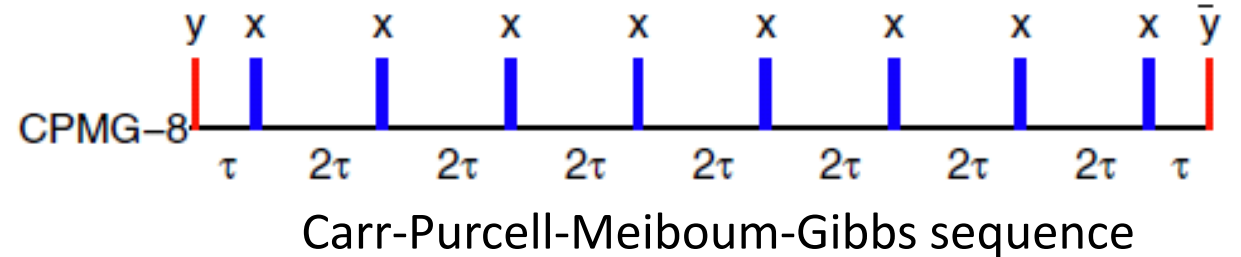

# Single spins in diamond

Diamond nitrogen vacancy center (NV Center)

- Principles of Optically-detected magnetic resonance (ODMR)
- Initialization, manipulation, read-out of NV electron spin

Environment: Diamond host material

 Applications



# Hybrid implementations

NV centers to superconducting microwave resonator

## Arrangement

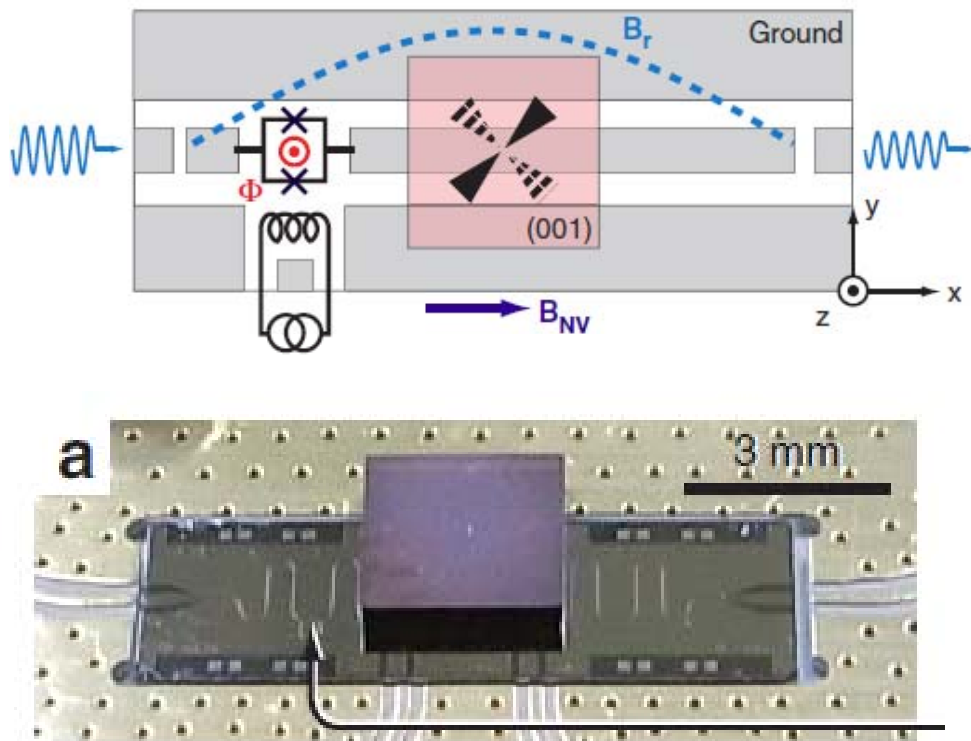

## Transmission vs. Frequency

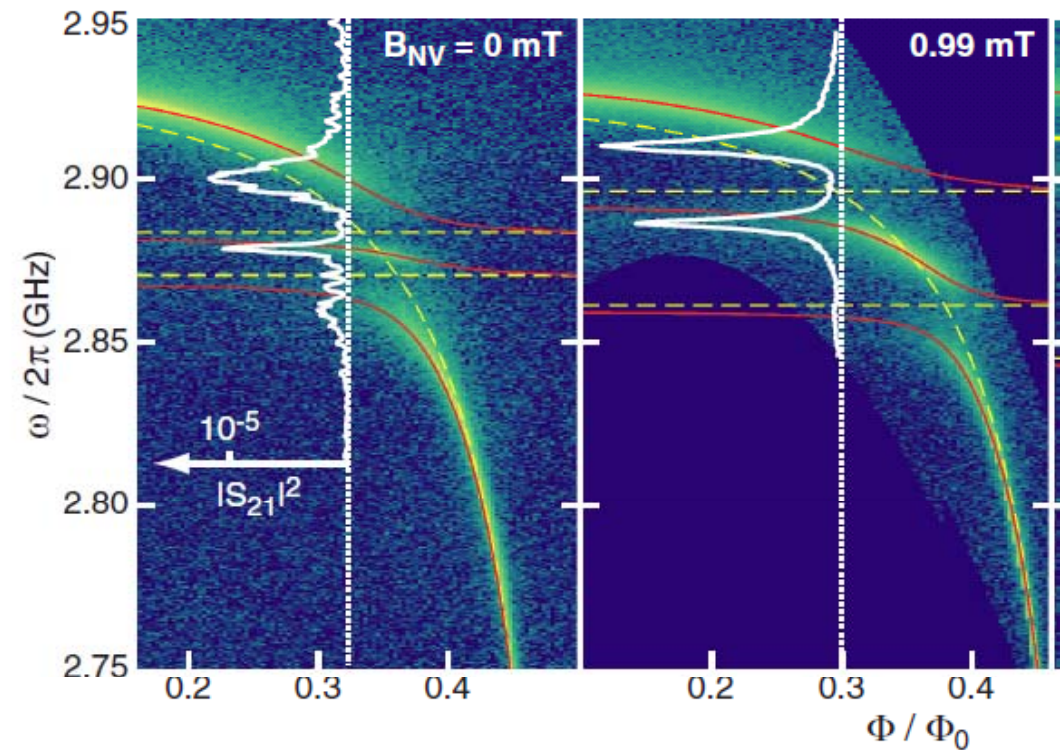

# Flux qubit

## Arrangement

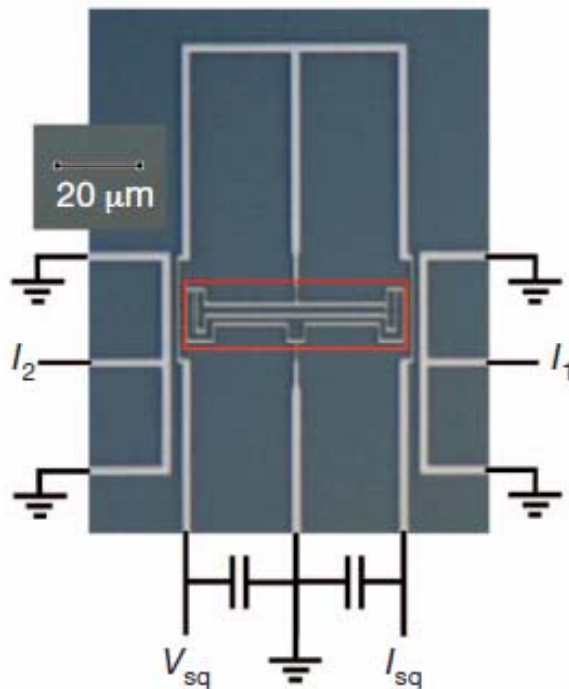
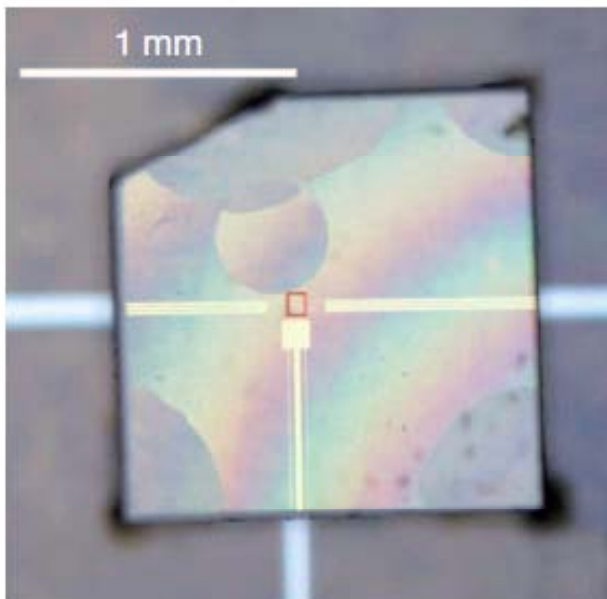

## Vacuum Rabi splitting

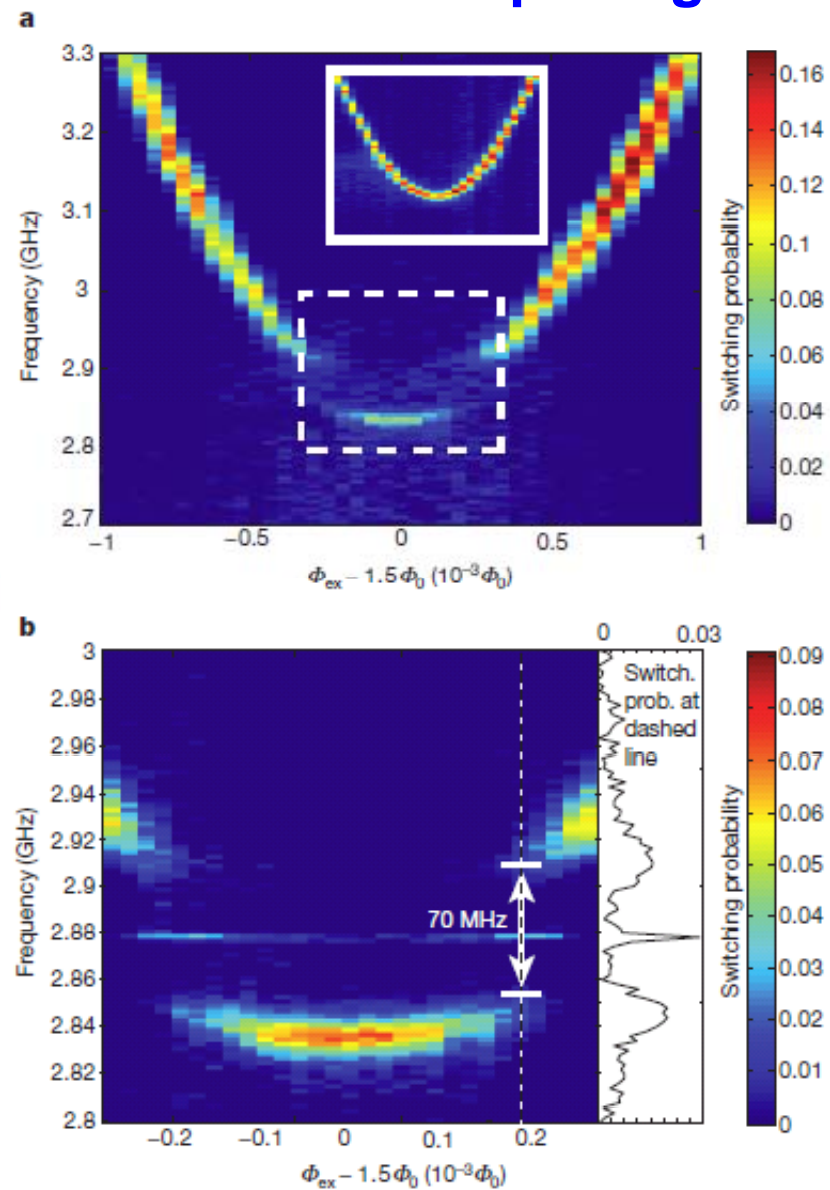



# Nanomechanical resonators

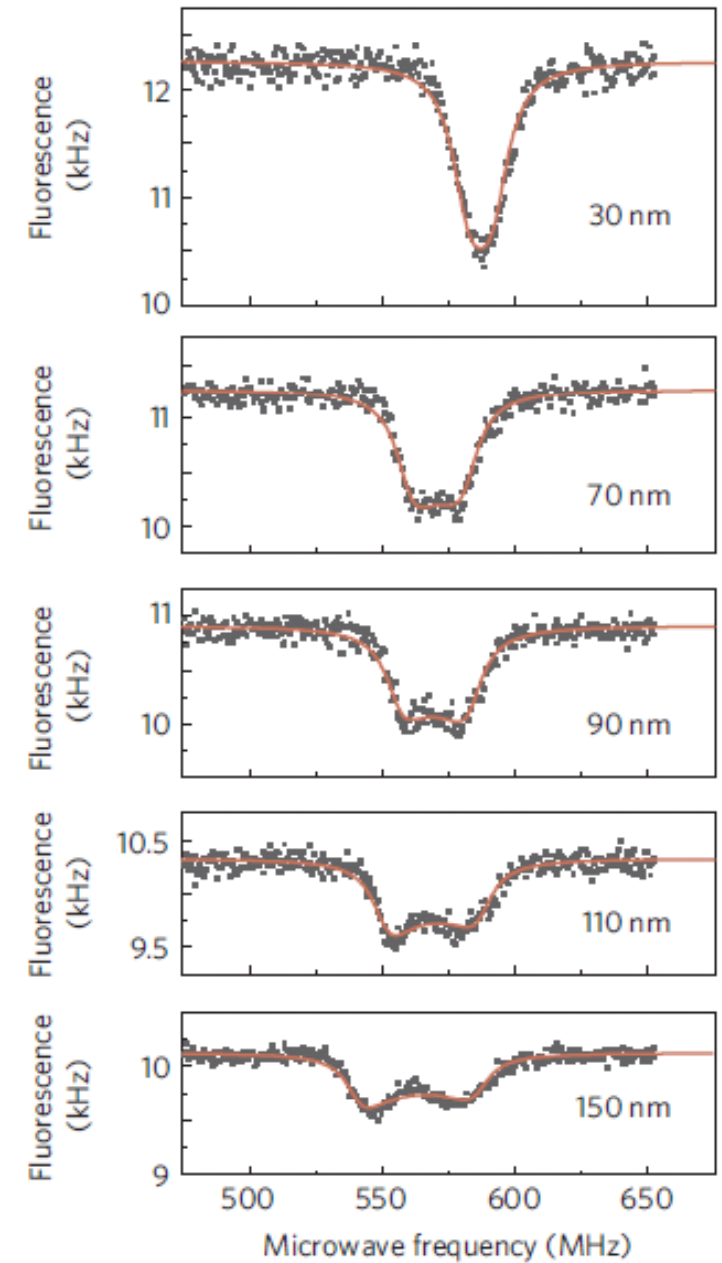
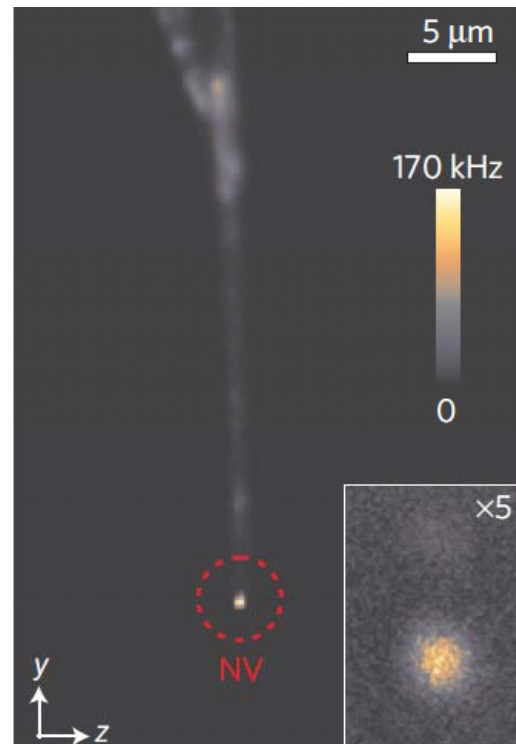
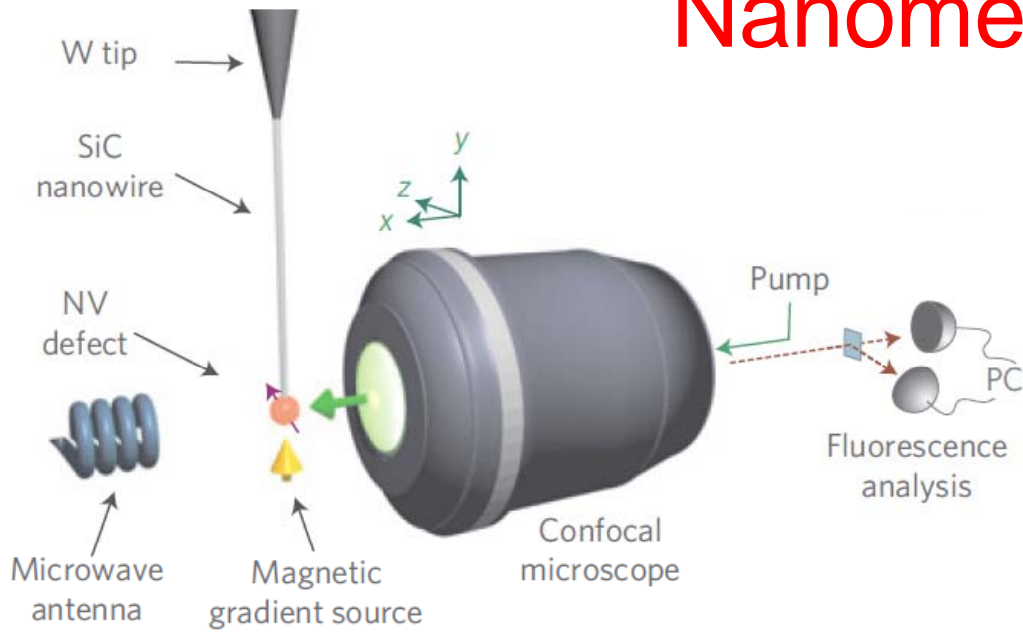

# Application in nanoscale magnetic imaging

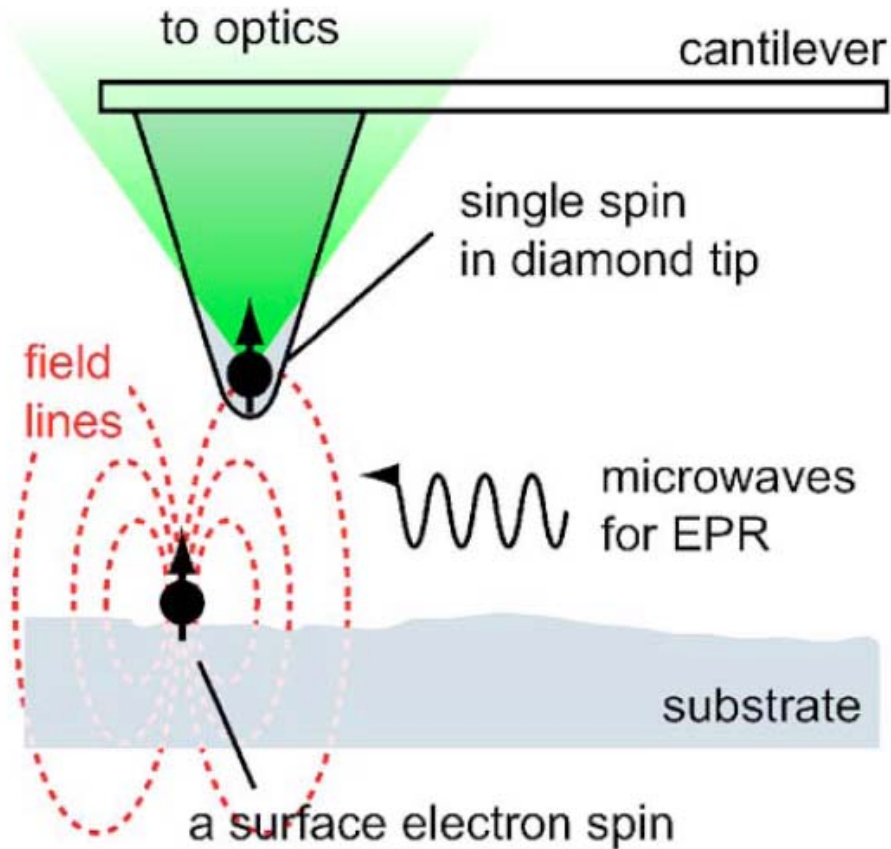

Measure nanoscale magnetic fields from:

- Single electron spins
- Nuclear spins in (bio)molecules
  - Superconductors
  - Magnetic nanostructures
- Quantized currents in mesoscopics

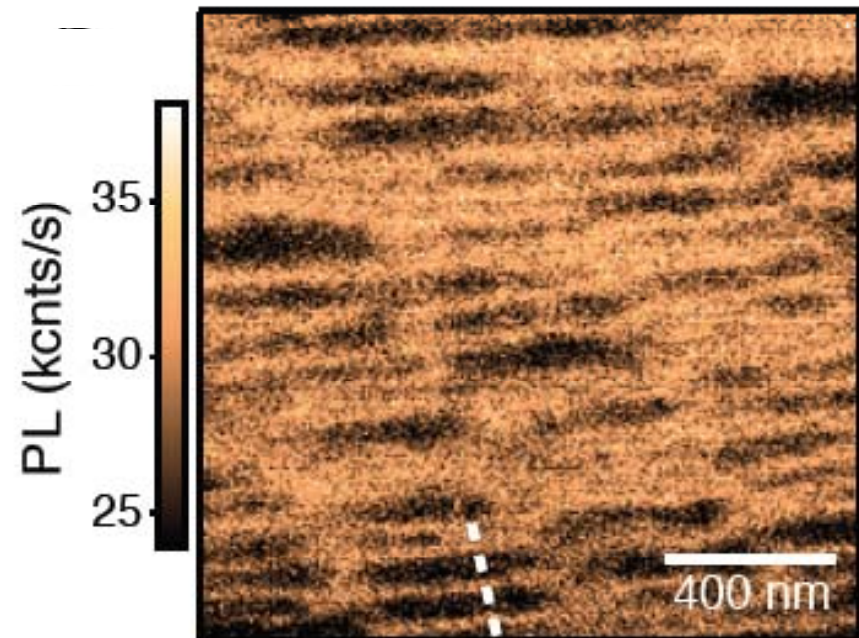

Degen, Appl. Phys. Lett, 2008

Disk drive (Rondin, arXiv, 2011)